

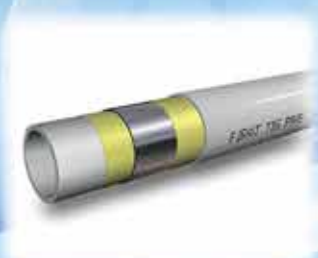



















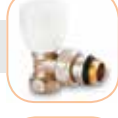





**FIRAT**

**PRODUCT  
CATALOGUE**





# CONTENTS

FIRAT		02 - 03
NEW PRODUCTS	  	04 - 05
PEX-AL-PEX PIPES	 	06 - 09
PERT-AL-PERT PIPES & PRESS FITTINGS	 	10 - 15
PE-X PIPES AND FITTINGS	 	16 - 19
METAL SYSTEMS		20 - 27
PPRC PIPES AND FITTINGS	 	29 - 43
DUBLEX PIPES AND FITTINGS	 	44 - 53
NEW RESIDENCE PIPES AND FITTINGS	 	54 - 59
RESIDENCE POWER PIPES AND FITTINGS	 	64 - 71
RAIN GUTTERS AND FITTINGS	 	72 - 77
PE PIPES		78 - 79
HOSES		80 - 85
DRAINAGE PIPES		86
OUR QUALITY CERTIFICATES & EXPORT MAP	 	87 - 88



## FIRAT

FIRAT was established to carry out production in the field of plastic building materials in the year 1972. FIRAT, which always sets out with the principles of **“Quality Production”** and **“Quality Products Diversity”**, has succeeded in becoming both the leading establishment of the sector and the export leader of the sector as a result of significant enterprises that have taken years.

In its production FIRAT targets various sectors such as construction, agriculture, automotive, medical, domestic appliances sectors with its plastic-based products. It realizes its production targeting those sectors in its modern factories in Büyükcçekmece-İstanbul and Sincan-Ankara.

FIRAT owns one of the three biggest plastic production complexes in Europe.

As of 2018 the number of personnel working in the constitution of FIRAT is 1850. Firat which believes that the most valuable element is human always organizes in-service trainings with the aim of enhancing work experience of its employees and building up their corporate knowledge.

### Product Diversity and Groups

FIRAT has a product range of over 5500 products. In order to ensure that our customers get the most beneficial and satisfactory service, Firat products are manufactured as integrated systems (parts complementing each other).

Thousands of FIRAT products, such as PVC window and door frames, PVC gutters, PVC drainpipes and attachments, PVC hose assemblies, rubber and PE-based hoses, PPRC indoor installation pipes and attachments, PP composite pipes and attachments, HDPE pipes and attachments, PP&PE sheets, LDPE pipes and attachments, EF attachments, PE attachments, PE 80 natural gas pipes, PVC and PE drainage pipes, FKS sewage pipes, FCS pipe systems, tunnel type drainage pipes, double-walled cable protection pipes, EPDM gaskets, TPE gaskets, metal injection products (hinges and window fittings), PEX mobile piping system and floor heating pipes, PEX pipes and metal attachments, PEX-AL-PEX pipes, sprinkler irrigation pipes and drip irrigation pipes are at the service of customers in Turkey and many other points in the world.





FIRAT manufactures FKS canalisation pipe, the testable operating life of which is 100 years. These pipes which can be manufactured up to 2400 mm diameter from HDPE (high density polyethylene) raw material are resistant against ground motion, gnawing animals, plant roots and chemical wastes. FKS pipes are manufactured with German company Krauh technology and licence.

Triplex pipes again manufactured in FIRAT facilities are used in out door installations and grounds as well as domestic connections, predominantly in sewer line, rain water drainage lines, industrial waste water installations, water conveying pipes and drainage systems. Triplex pipe has big advantages like high flow performance, external load resistance, long operating life, transport and storage convenience, its becoming economic, endurance against chemical substances, price and maintenance convenience, imperviousness and filter-free operation choice.

FIRAT is capable of conducting welding, heavy rain and wind resistance, blow and milled blow resistance,

compression, shear and break-off strength ring rigidity (strength of FKS and Triplex pipes against soil load) tests in its the state-of-the-art test and analysis laboratories. Our products are offered to the service of our customers only after they are confirmed by the Quality Assurance Group related to their conformity to production, sale and outlet.

After all the quality control tests are completed, FIRAT products are offered to the market with Firat Quality Assurance Confirmation". Firat is the only company of the sector which holds international quality certificates such as GOST, SKZ, BDS, EMI, DVGW, TSE as well as ISO/IEC 17025 accreditation and all of the system certificates, which are ISO 14001, OHSAS 18001, ISO 10002 and ISO 9001. As an environmentally friendly manufacturer, Firat holds an ISO 14000 Environment Management System Certificate.

To develop, grow, struggle to achieve perfection through advanced technology and utilize all its resources in order to ensure long lasting customer satisfaction are the objectives of FIRAT.



# New Products

**NEW PRODUCT** PPRC FITTINGS

**Y - Filter**  
(Male-Female)



**Ball Valve**  
Ø50, Ø63, Ø75



**Reducing Elbow 90°**  
Ø25-20 and Ø32-25



**Reducing Socket**  
(160-125 / Female-Female)



**Ball Valve**  
(Metal Handle & Long Type)



**Elbow With Loose Nut**



**T With Loose Nut**



**Reducing Corner T - Piece**



**Radiator Valve**  
(Angled)



**Radiator Valve**  
(Straight)



**Socket With Loose Nut**



**Short Bridge**



**Armature Connector**  
For Bidet



**Plastic Union**



**Transition Nipple**  
(Female)



**Long Plug**  
(Type 2)



## New Products

### NEW PRODUCT METAL FITTINGS

1/2" Radiator Valve  
(Angled)  
(New Type)



1/2" Radiator Valve  
(Angled)  
(Pex Pipe Connection)



Ball Valves  
For Potable Water  
(Pn10)



Gas Ball Valve  
For Gas Systems  
(Pn10)



Ball Valves  
For Industrial Purposes  
(Pn10)



### NEW PRODUCT PVC DUBLEX FITTINGS

S - Siphon



Single Branch (45°)



Clean out Elbow  
110mm / 87°



S - Siphon With Muff



### NEW PRODUCT RED PE-Xb PIPES IN COVER

Red Pe-Xb Pipes



1" Manifold With Ball Valve  
(Red-Blue / Outlets:1/2" / Dn25)



1" Manifold  
(Red-Blue / Outlets:1/2")

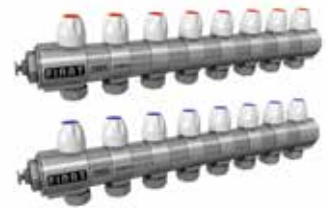

### NEW PRODUCT GEDIZ PIPES

Gediz Pprc Composite Pipes  
(Fiber Glass Reinforced)



Gediz Pprc Pipes



## Pex-Al-Pex Pipes (Multi Layer Tig Pipes)

TIG Pipes are used for warm and cold water systems, radiator systems, pressured air installations, transmission of cooled fluids, inner-building fresh water systems and floor heating systems. TIG Pipes are produced through a special technology combining the superior features of plastic and metal materials. While the inner and outer layers of TIG Pipes are made of polyethylene, aluminum is used for the production of the middle layer.

The name of this special pipe is derived from the special method used to produce it. Aluminum layer is twisted over the polyethylene layer (its molecule structure includes cross linked PE-Xb) and these two materials are then fixed with arc welding (Tungsten Inert Gas).

Inner and outer surfaces of TIG Pipes are formed by PE-Xb layers which are resistant to high temperatures, hygienic, resistant to corrosion and impacts taking root of external influences, very smooth and which are preventing sedimentation, providing excellent isolation.

In addition to these, a special adhesive and method is used for fixing the inner and outer PE-Xb layers with excellent properties to the aluminum layer.



### **Welding Technology Used for the Aluminum Layer of Tig Pipes**

The welding technique named as Tungsten Inert Gas has been considered to be a very important technological development by the plastics industry in recent years. This method includes bending the aluminum layer onto the PE-Xb inner layer and then fixing these two layers through arc butt welding. This technology surpasses the old technologies like overlapping in terms of life time and reliability.



# Pex-Al-Pex Pipes (Multi Layer Tig Pipes)

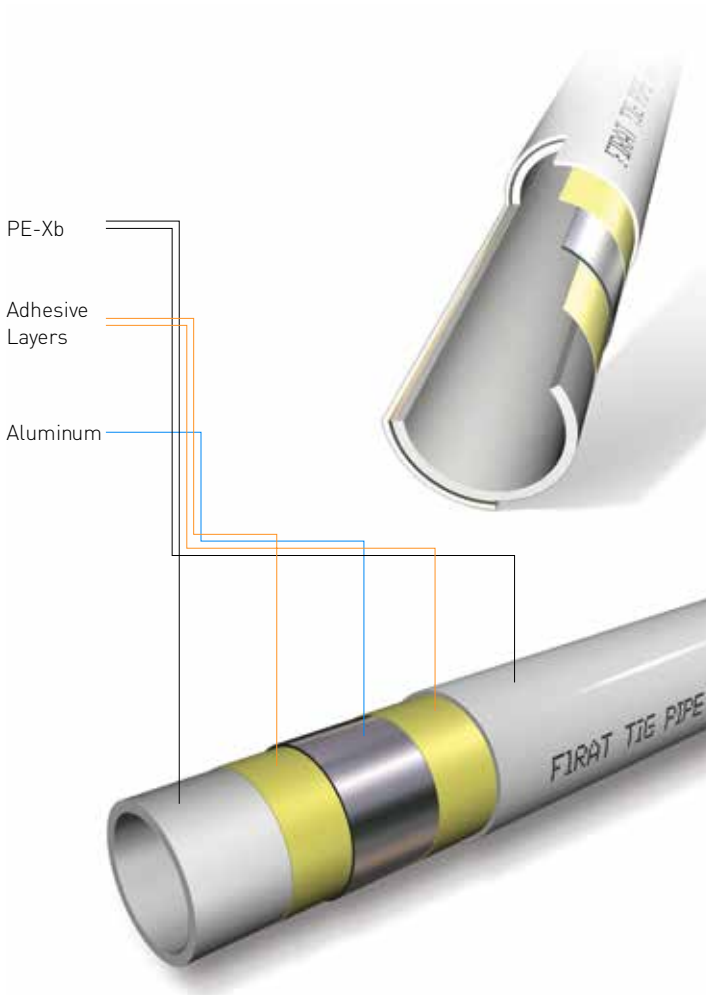

**PE-Xb:** Polyethylene surface with high resistance.

**Aluminum :** Aluminum surface entirely covering the inner PE-Xb surface.

**Adhesive Layers :** High strength bindingsurfaces for binding aluminum and PE-Xb surfaces.

## Advantages Provided by PE-Xb Layers

- The outer layer made of PE-Xb prevents corrosion on construction materials (lime, mortar etc.) and the aluminum layer of the pipe. It also provides resistance against impacts.
- The smooth surface of the PE-Xb inner layer both decreases the pressure value and also prevents sedimentation.
- Thermal conduction property of PE-Xb is excellent. Thanks to this, energy saving is possible for hot-water applications.
- The cross-linking PE-Xb forming the inner layer fulfills the human-health requirements for liquid foodstuff and fresh water applications.
- TIG Pipes produced from PE-Xb raw material are ideal for conveying acidic and alkaline fluids thanks to the properties of the raw material.

## Specifications for PE-Xb

Density	0,950 gr/cm <sup>3</sup>
Water temperature (application)	+95 °C
Softening temperature	135 °C
Thermal conductivit	0,37 kcal/m h °C
Cross-linking degree (minimum)	65 %
Elongation at break	500-600 %
Breaking strength (at 20 oC)	290-300 kg/cm <sup>2</sup>



# Pex-Al-Pex Pipes (Multi Layer Tig Pipes)

## The Relation between Tig Pipes and Oxygen

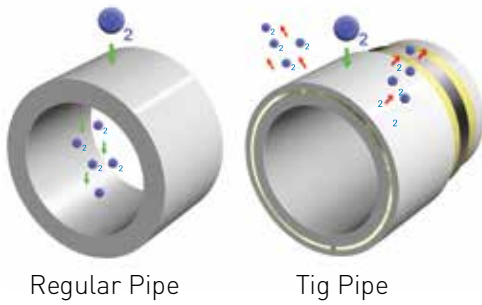

## Properties of Cross-Linking Polyethylene (PE-Xb)

Currently, pipes produced from HDPE raw material are used for conveying fluids with maximum temperature of 50°C. However, even at 50°C, it is a must to exercise a pressure lowering factor. On the other hand, pipes made of cross-linking polyethylene (PE-Xb) present an excellent capacity to convey hot water with temperature values higher than 50°C. Service life problem for pipes, related to hot water conveying, is eliminated with the use of cross-linking PE-Xb.

Cross-linking process forms polymer chains between micro-molecules. This process, conducted with Silan method (PE-Xb), delivers a much longer service life for pipes.

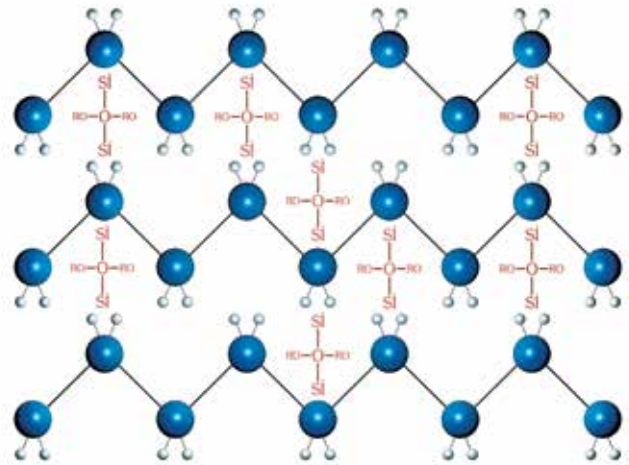

PE-Xb with cross-linking

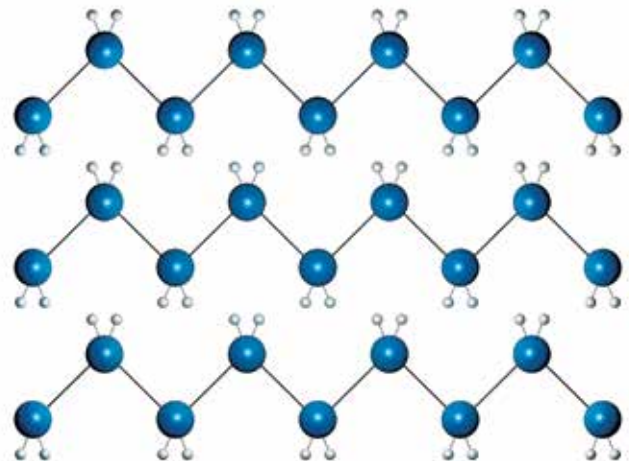

PE without cross-linking

## Pex-Al-Pex Pipes (Multi Layer Tig Pipes)

### PE-Xb -AL-PE-Xb PIPES

CODE	ØD(mm)	d(mm)	t(mm)	L(coil/m)
7495000014	14	14	2	100
7495000017	16	16	2	100
7495000018	16*	16	2*	200
7495000015	16*	16	2*	100
7495000016	16*	16	2*	300
7495000019	18	18	2	100
7495000020	20	16	2	100
7495000021	20*	20	2*	100
7495000025	25	20	2.5	50
7495000026	26*	25	3*	50
7495000027	25*	26	5*	50
7495000032	32*	32	3*	50

\* Without carton box package

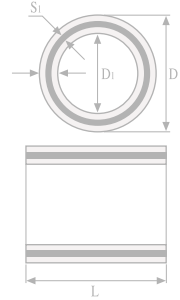

### PE-Xb -AL-PE-Xb PIPES IN COVER

CODE	ØD(mm)	d(mm)	t(mm)	L(coil/m)
7490004016K Red	16	16	2	50
7490004016M Blue	16	16	2	50
7490004020K Red	20	20	2	50
7490004020M Blue	20	20	2	50

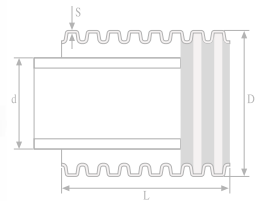

## Pert-Al-Pert Pipes (Multi Layer Pipes)

FIRAT multilayer PERT-AL-PERT pipes are used for hot and cold water applications and underground heating systems. Multilayer composite pipe is flexible, can be easily shaped by hand, and maintain its form. This is why pipes are suitable to apply different ground, pavement and wall type systems with varieties of plumbing.

FIRAT PERT-AL-PERT pipes are produced according to German Standard SKZ HR 3.12 (Application Class 4)

Max Operating Temperature: **95°C**

Max Operating Pressure: **10 bar**

Min Bending Radius: **5 x Outer Diameter**

Thermal Conductivity: **0,45 W/m K**

Thermal Expansion Coefficient: **0,026 mm/m K**

### **PERT-AL-PERT** (Five Layered Composite Pipes)

- Long Service Life
- Low thermal conductivity
- High temperature and corrosion resistance
- Hygienic and Environmental Friendly

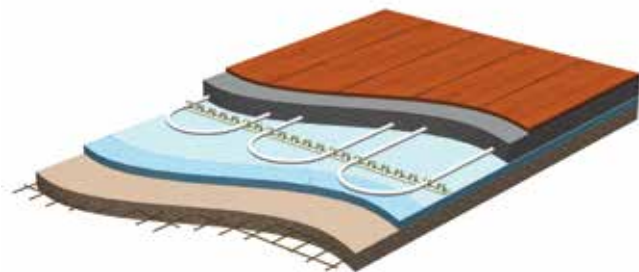

**Inner Layer:** Smooth and Clear PERT Surface provides great water flow and have all properties and advantages the of PERT.

**Adhesive Layer:** This special and highly adhesion layer keeps layers together as one in tough conditions.

**Aluminum Layer:** Integrated to inner layer with adhesive and maintains maximum oxygen impermeability to protect metal components from corrosion.

**Adhesive Layer:** This special and highly adhesion layer keeps layers together as one even in tough conditions.

**Outer Layer:** Have all the properties and advantages of PE-RT ro metarial Protects Aluminum core from outside effects and helps to stand against high temperatures.

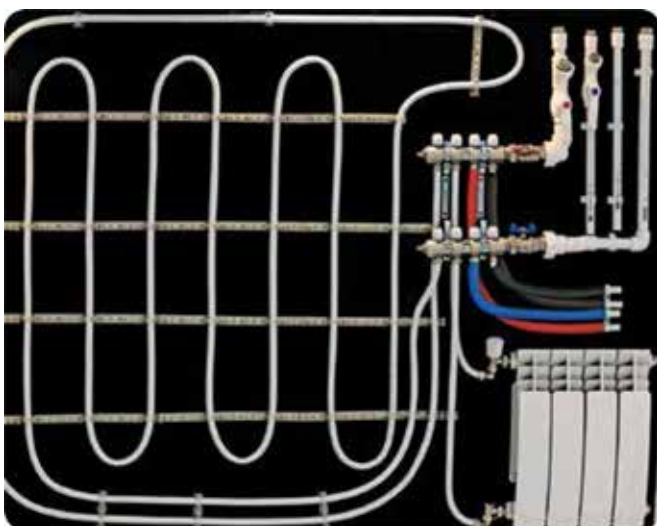

PERT-AL-PERT Pipe has special welding technique named as Tungsten Inert Gas this has been considered to be a very important technological development by the plastics industry in recent years. This method includes bending the aluminum layer onto the PE-RT inner layer and then fixing these two layers through arc butt welding.

# Pert-Al-Pert Pipes (Multi Layer Pipes)

## Raw Material

PE-RT: Polyethylene of Raised Temperature Resistance  
 PE-RT has a higher; Long-Term Hydrostatic strength (LTHS) and Mechanical properties in hot water applications.

Physical Properties	Test Method	Unit	S.I.
Melt Index	ISO 1133	g/10 min.	0,55
Melt Index	ISO 1133	g/10 min.	1,85
Density	ISO 1183	g/cm <sup>3</sup>	0,941
Vicat Softening Point	ISO 306	°C	124,7
Thermal Conductivity	DIN 52612-1	W/(mK)	0,4
Thermal Expansion Coefficient	DIN 53752 A	10 <sup>-4</sup> /K	1,8

Mechanical Properties	Test Method	Unit	S.I.
Hardness, Shore D	ISO 868	-	60,5
Tensile Yield	ISO 527-2	Mpa	20,3
Tensile Yield Elongation	ISO 527-2	%	14
Ultimate Tensile	ISO 527-2	Mpa	37
Ultimate Elongation	ISO 527-2	%	780
Flexural Modulus	ISO 178	Mpa	660
Elastic Modulus (1)	ISO 527-2	Mpa	645
Izod Impact	DIN 180	kJ/m <sup>2</sup>	23,0

## PERT-AL-PERT PIPES

CODE	ØD (mm)
<b>7496001014</b>	<b>14x2</b>
<b>7496001016</b>	<b>16x2</b>
<b>7496001018</b>	<b>18x2</b>
<b>7496001020</b>	<b>20x2</b>
<b>7496001025</b>	<b>25x2.5</b>
<b>7496001026</b>	<b>26x3</b>
<b>7496001032</b>	<b>32x3</b>



## PERT-AL-PERT PIPES IN COVER

CODE	ØD (mm)
<b>7496004016K Red</b>	<b>16x2</b>
<b>7496004016M Blue</b>	<b>16x2</b>
<b>7496004020K Red</b>	<b>20x2</b>
<b>7496004020M Blue</b>	<b>20x2</b>

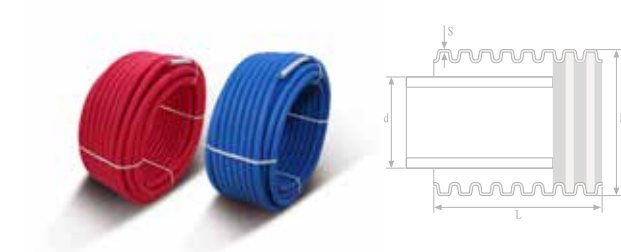

## Press Fittings (For Multi Layer Pipes)

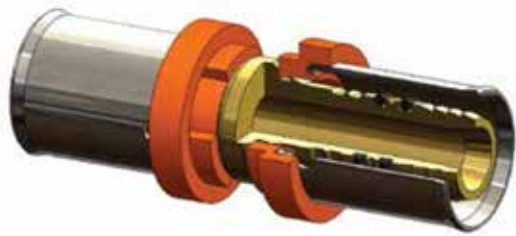

**Tig Pipe Press Fittings are suitable for:**

- hot and cold water supply systems,
- heating systems,
- industrial applications

Press Fittings can be used with Pex-Al-Pex and Pert-Al-Pert pipes.



1. Products should be stored in its original packaging which is protected against dust which may come from outside during storage, transportation and installation. Press fitting should not be kept in dusty and corrosive environment.
2. Connection system; The fitting consist of a Plastic Ring, Sleeve and O-Ring. Fittings with missing elements should not be installed.
3. Fitting must be removed from the package when installed and installing should done by competent personnel.
4. Fittings must be used in water systems, not in flammable and combustible gas systems.
5. External factors (dirt, sand, burrs, etc.) in the installation should be cleaned before installation
6. The surface of the pipe to be installed must be cut perpendicularly axis and not to be crushed and smashed, it must be free from particuls, the pipe must be calibrated with the special tool calibrator.
7. Special should be paid that the fittings and the connecting parts are coaxial. The same axial and non-bracing installation should not be aplicated.
8. The pipe to be installed must be clearly seen through the observation holes on the Press Metal Ring, otherwise the installing and pressing process should not be done.
9. Press fitting pressing process must be performed using the diameter and jaw types specified on the Press Metal Ring (TH-H-U).
10. Only suitable teflon tape should be used on the threads of the fittings.
11. Installation Process must only be done with the appropriate size key from the key mouth parts during the installation.
12. Fittings should not be used with the pipe connections without ensure adequate flow and proper control.
13. Non-abrasive materials must be used on the surface of the fittings during cleaning and painting operations.

## Press Fittings (For Multi Layer Pipes)

### DOUBLE NIPPLE

CODE	ØD (mm)
7800351001	16x16
7800351002	20x20



### DOUBLE REDUCED NIPPLE

CODE	ØD (mm)
7800354001	16x20



### NIPPLE WITH FLOT-FACED CONNECTION

CODE	ØD (mm)
7800355001	16x1/2"
7800355002	20x1/2"
7800355003	20x3/4"



### MALE NIPPLE

CODE	ØD (mm)
7800355101	16x1/2"
7800355102	20x1/2"
7800355103	20x3/4"



### FEMALE NIPPLE

CODE	ØD (mm)
7800355201	16x1/2"
7800355202	20x3/4"
7800355203	20x1/2"
7800355204	20x3/4"



## Press Fittings (For Multi Layer Pipes)



### FEMALE ELBOW

CODE	ØD (mm)
7800356001	16x1/2"
7800356002	20x1/2"
7800356003	20x3/4"



### MALE ELBOW

CODE	ØD (mm)
7800356101	16x1/2"
7800356102	20x1/2"
7800356103	20x3/4"



### ELBOW

CODE	ØD (mm)
7800352001	16x16
7800352002	20x20



### WALL PLATE ELBOW

CODE	ØD (mm)
7800357001	16x1/2"
7800357002	20x1/2"
7800357003	20x3/4"

## Press Fittings (For Multi Layer Pipes)

### FEMALE T

CODE	ØD (mm)
7800358001	16x1/2"x16
7800358002	20x1/2"x20
7800358003	20x3/4"x20



### MALE T

CODE	ØD (mm)
7800358101	16x1/2"x16
7800358102	20x1/2"x20
7800358103	20x3/4"x20



### TEE

CODE	ØD (mm)
7800353001	16x16
7800353002	20x20



### REDUCED T

CODE	ØD (mm)
7800353101	20x16x16
7800353102	20x20x16
7800353103	16x20x16
7800353104	20x16x20



# FIRATPEX Pipes and Fittings

Polyethylene based FIRATPEX Pipes System as the smart product of the plastic technology is the single pipe system which can be used in hot-cold water installations, underfloor heating, portable and clean water systems.

Thanks to their flexible structure, FIRATPEX Pipes can be used comfortably in different forms in different floor, furnishing and wall types and as sheathed in radiator systems which are so-called as portable installation as well as any kind of sanitary installation systems.

FIRATPEX Pipe Systems is the best installation solution for heating different buildings such as business complexes, residents, sports halls, schools, laboratories, chapels, theatres etc.

Due to its nature, polyethylene cannot resist against hot fluids, however, if their molecular chain structure is transformed into crosslink-PE-Xb structure, they become durable against very high temperatures. FIRATPEX Pipes based on cross-linked polyethylene can operate in all temperatures between -100 °C and +110 °C without deterioration in its structural properties.



### Sheathed Firatpex Pipes

Sheathed Firatpex Pipes are generally used in radiator systems, also called as portable installation and cold-hot water installations and it is applied by placing a spiral sheath inside the PEX pipe.

### Advantages of Sheath (Protective Spiral Pipe)

1. Sheath prevents abrasion of PEX Pipes.
2. Sheath Prevents the impacts that may be directed onto PEX pipes.
3. Sheath ensures easy replacement of pipes without removing flooring if PEX pipes are damaged.
4. Sheath maintains heat insulation and prevents water losing its heat by forming an air gap between PEX pipe and screed concrete.



### Service Life of PE-Xb Pipes

Guaranteed service life of Firatpex pipes is 50 years under 12.5 bar pressure at 20 °C. Moreover, Firatpex pipes can achieve 50 years of service life under 7.1 bars at 70 °C.

### PE-Xb Pipe Diameter Values

Rated Diameter External Diameter (mm)	Wall Thickness (mm)
14	2.0
16	2.0
17	2.0
18	2.0
20	2.3
25	2.8
32	3.6



# FIRATPEX Pipes and Fittings

## Crosslink

FIRATPEX Pipes are produced with extrusion method. Later formed into a coil, FIRATPEX Pipes are placed in steam tanks and cured for approx 4 hours. As a result, polymer chains are linked with side chains and turns into one molecule and transformation into cross linked structure is completed.

## Crosslink Types

There are different types of pex pipe systems as PEX-a Peroxide, PEX-b Silane and PEX-c Irradiation (Difference between types depends on production method and crosslink ratios stipulated by TS 10762-2 EN ISO 15875-2 Standard).

PE-X<sub>a</sub> is also known as peroxidised method. Before extrusion, peroxide is mixed with PE rawmaterial. Crosslink is maintained during production. It is the oldest method known. The crosslink degree must be 70% at least.

PE-X<sub>b</sub> is also known as silane method. It is produced with mixing cross linkable High Density Polyethylene which is resistant against heat and pressure and a special liquid called as "silane" at specified ratio. Crosslink is facilitated with steam cure which is a special process after production. The crosslink degree must be 65% at least.

PE-X<sub>c</sub> is known as irradiation method. It is produced from High Density Polyethylene rawmaterial having high molecular weight. Cross link is maintained with irradiation process after production. The crosslink degree must be 60% at least.

FIRATPEX Pipe Systems are produced with PE-X<sub>b</sub> method which is also known as Silane Method since high performance against temperature and flexibility features.

FIRATPEX Pipe Systems are produced in four different types according to application areas in line with TS 10762-2 EN ISO 15875-2 standard.

1. PEX Pipes with Oxygen Barrier.
2. Self-Sheathed PEX Pipes with Oxygen Barrier.
3. PEX Pipes without Barrier.
4. Self-Sheathed PEX Pipes without Oxygen Barrier.

## FIRATPEX Pipes with Oxygen Barrier

Due to oxygen permeability feature of plastic materials, they allow the oxygen penetration into water from outside in heating systems. In such cases, oxidisation and corrosion can be seen in radiator, natural gas boiler, boiler and installation. In order to eliminate this problem, external surfaces of PEX pipes are coated with a bright layer which is insulated against oxygen transmission between inside and outside of pipe with a special method during production, so that their tightness against oxygen is maintained. Therefore, oxygen is prevented to be transmitted into water inside installation and no corrosion and oxidation can certainly be seen.

## Oxygen Permeability Amount Determination: DIN 4726

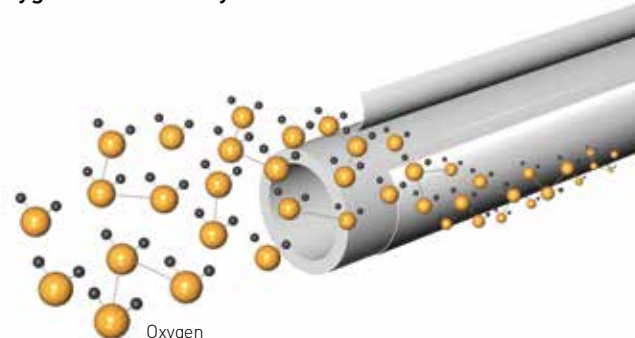

### 1. Mechanic Properties

\* For Ø 16mm

Hydrostatic Tension (MPa)	Test Temperature (°C)	Test Time (Hour)	Test Pressure (Bar)
12	20	1	34.3
4.8	95	1	13.8
4.7	95	22	13.5
4.6	95	165	13.2
4.4	95	1000	12.6

### 2. Physical and Chemical Properties

	Requirement	Parameter (°C)	Time (Hour)
Dimensional Stability	≤ % 3	120	1
Cross Linking Operation	≥ % 65		
Thermal Stability by means of Hydrostatic Pressure Test	No deformation should occur	2.5 MPa 110 °C	8760

# FIRATPEX Pipes and Fittings

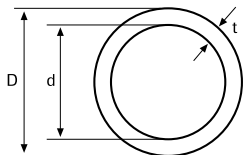

## PEX PIPES (Pipes with Oxygen Barrier)

CODE	ØD (mm)	d (mm)	t (mm)	L (mm)
<b>74900010014</b>	14	10	2	160
<b>74900010016</b>	16	12	2	160
<b>74900010017</b>	16	11.6	2.2	160
<b>74900010019</b>	17	13	2	160
<b>74900010024</b>	18	14	2	160
<b>74900010025</b>	18	13	2.5	160
<b>74900010020</b>	20	16	2	100
<b>74900010021</b>	20	15.4	2.3	100
<b>74900020027</b>	25	19.4	2.8	160
<b>74900010032</b>	32	24.8	2.6	50

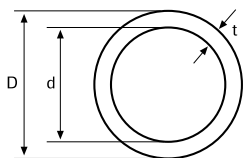

## PEX PIPES (Pipes without Oxygen Barrier)

CODE	ØD (mm)	d (mm)	t (mm)	L (mm)
<b>74900020014</b>	<b>14</b>	10	2	160
<b>74900020016</b>	<b>16</b>	12	2	160
<b>74900020017</b>	<b>16</b>	11.6	2.2	160
<b>74900020019</b>	<b>17</b>	13	2	160
<b>74900020024</b>	<b>18</b>	14	2	160
<b>74900020018</b>	<b>18</b>	13	2.5	160
<b>74900020020</b>	<b>20</b>	16	2	100
<b>74900020021</b>	<b>20</b>	15.4	2.3	100
<b>74900020027</b>	<b>25</b>	19.4	2.8	160
<b>74900020032</b>	<b>32</b>	24.8	2.6	50

## SPIRAL COVERED PEX PIPES

Pipes with Oxygen Barrier\*

CODE	ØD (mm)	d (mm)	t (mm)	L (mm)
<b>7490003116K Red</b>	24.5	16	2	100
<b>7490003116M Blue</b>	24.5	16	2	100

\* Sheathed FIRATPEX pipes with oxygen barrier are produced as red and blue spiral sheathed.

Pipes without Oxygen Barrier\*\*

CODE	ØD (mm)	d (mm)	t (mm)	L (mm)
<b>7490003016K Red</b>	24.5	16	2	100
<b>7490003016M Blue</b>	24.5	16	2	100

\*\*Sheathed FIRATPEX pipes without oxygen barrier are produced as red and blue coexed spiral sheathed.

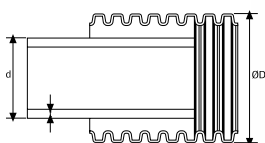

# FIRATPEX Pipes and Fittings

## SPIRAL SHEATHS

CODE	ØD (mm)	d (mm)	t (mm)	L (mm)
<b>7321000191K Red</b>	24.5	19.5	2.5	100
<b>7321000191M Blue</b>	24.5	19.5	2.5	100
<b>7321000192K Red</b>	24.5	23.1	2.55	100
<b>7321000192M Blue</b>	24.5	23.1	2.55	100

Ø16mm  
P E X  
Spiral

Ø20mm  
P E X  
Spiral

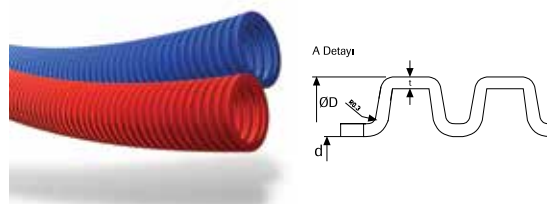

## CORNER FIXER\*

CODE	ØD (mm)	A (mm)	H (mm)	T (mm)	L (mm)
<b>74910000016</b>	16	24.3	94.5	35.5	119.5

\* 8x10 box, including chock and ring.

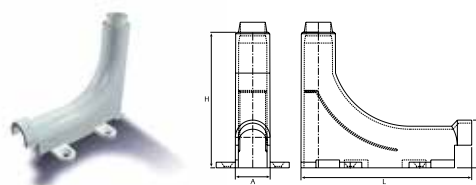

## FISH PLATE WITH CLIPS

CODE	ØD (mm)	H (mm)	T (mm)	L (mm)
<b>74920000016</b>	16	23	47.3	330

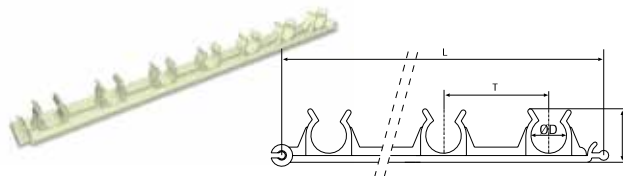

## DOUBLE RETAINING CROCHET

Code	ØD (mm)	H (mm)	A (mm)	L (mm)
<b>7494002525</b>	16	63	8	61.5



## PERT PIPES (Pipes with Oxygen Barrier)

CODE	ØD (mm)	d (mm)	t (mm)	L (mm)
<b>7496000014</b>	14	10	2.2	160
<b>7496000015</b>	16	12	2	160
<b>7496000017</b>	17	11.6	2	160
<b>7496000018</b>	18	13	2.5	160
<b>7496000021</b>	20	16	2	100
<b>7496000025</b>	25	19.4	2.8	160
<b>7496000026</b>	26	19.4	2.8	160
<b>7496000032</b>	32	24.8	3.6	50

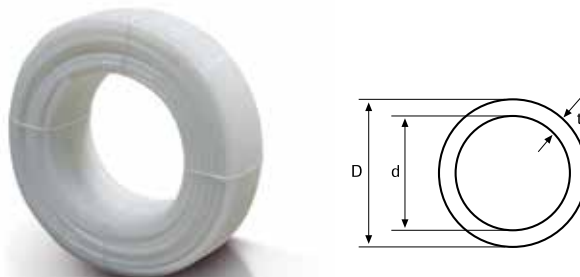

## PERT PIPES (Pipes without Oxygen Barrier)

CODE	ØD (mm)	d (mm)	t (mm)	L (mm)
<b>7496000016</b>	16	12	2	160
<b>7496000019</b>	17	11.6	2	160
<b>7496000022</b>	19	16.0	2	100

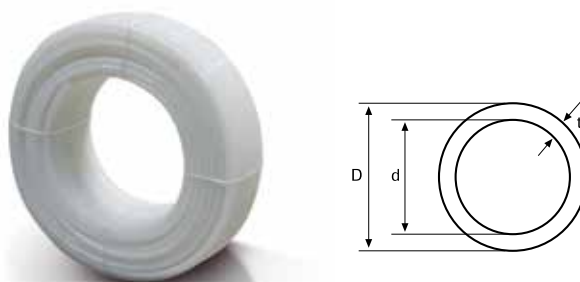

## Metal Systems

### **Production**

Metal Fittings are subjected to various processes until they become a finished product from brass rawmaterial. These processes are lined up as follows;

- Supplied in form of bars, brass rawmaterial is cut to required dimensions and weights using automatic saws and prepared for forging process.
- Heated in high temperature ovens, brass bars are forged with automatic presses and turned into semi-finished product.
- Pressed product is sandblasted and processed in robotic full-automatic machinery and prepared for nickel plating.
- Nickel plated products, accessories and sealing elements are assembled in fully automatic machinery
- All Metal Fittings are subjected to 100% tightness test upon assembly.
- Metal Fittings which pass the tightness test are packaged automatically and made ready for shipping.

### **Brass**

Firat uses special CU 617N (MS 58) Brass as rawmaterial for the production of Metal Fittings. Brass is preferred in production of metal fittings due to its ease of process, extended usage life, high resistance to abrasion and corrosion. Supplied in form of bars, brass rawmaterial is manufactured as per EN 12164 and EN12165 standards.

### **EPDM O-Ring**

Perfect functioning of Firat Metal Fittings can only be ensured by using correct O-Ring in the system. Ethylene Propylene Diene Monomer (EPDM) is used as the most suitable rawmaterial among synthetic rubbers for O-rings used with Firat Metal Fittings. The only gasket which is resistant to air-water oxidation, ozone cracking is the only EPDM rubber product which has permanent deformation values required for tightness between temperatures  $-40^{\circ}\text{C}$  and  $+130^{\circ}\text{C}$ .

### **Nickel Plating**

Firat Metal Fittings made of MS 58 Brass are available in nickel plating. With nickel plating, fittings have a shining and beautiful appearance and their outer surface corrosion resistance increases and it provides a longer useful life.



## Metal Systems

### Radiator Valves

Firat metal ball valves are fittings used by plumbers while carrying out opening-closing etc. checks and tests by installing them to the input parts of the collectors employed in FIRAT PEX floor heating systems, FIRAT PEX mobile heating systems, FIRAT PEX water supply systems and similar systems. Housing, internal mechanism and connections of Firat metal ball valves are made of MS 58 brass material and EPDM O-Ring and PTFE (Teflon) are used for ensuring tightness.

Firat ball valves are subjected to the following tests as per TSEK\* quality criteria.

- External Leakage Test in Closed Position
- Internal Leakage Test in Open and Closed Position
- Pressure Test
- Thickness of Coating Test (It is applied on the material in addition to standard tests.)

### Installation and Usage Information for Ball Valves

- The valve is designed for heating systems. It shall not be used for flammable-burning gas systems.
- System pressure shall not exceed 25 bars and operating temperature shall not exceed 105°C.
- For mini ball valves system pressure shall not exceed 16 bars.
- Installation of the valve shall be carried out by a qualified plumber.
- All foreign substances (dirt, sand etc.) in the system shall be cleaned before installation.
- The valve shall only be installed with original fittings.
- Installation direction shall be determined according to the arrow sign on the valve housing which show the flow direction.
- Threaded parts of the fittings shall be covered with suitable sealing materials (teflon tape).
- The valve shall be tightened from the corresponding section using a suitable wrench during installation. The valve shall not be tightened by using the housing.
- Adjustment knob shall not be forcibly rotated past the end and the valve shall be used in fully open or fully closed positions.
- Abrasive chemicals shall not be used to clean the valve.
- System shall be protected against risk of freezing.
- It shall be protected against external impacts during storage, shipping, installation and operation.
- Useful life established and announced by Ministry is 5 years.



# Metal Systems

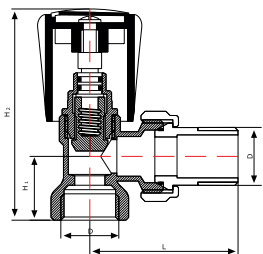

## 1/2" RADIATOR VALVE (ANGLED)

CODE	ØD (mm)	G"	H <sub>1</sub> (mm)	H <sub>2</sub> (mm)	L (mm)	Working Pressure
7800110600	DN 15	1/2"	23	76.25	53.44	PN 10

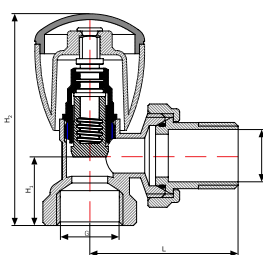

## 1/2" NEW RADIATOR VALVE (ANGLED)

CODE	ØD (mm)	G"	H <sub>1</sub> (mm)	H <sub>2</sub> (mm)	L (mm)	Working Pressure
7800110620	DN 15	1/2"	22	66.60	46.70	PN 10

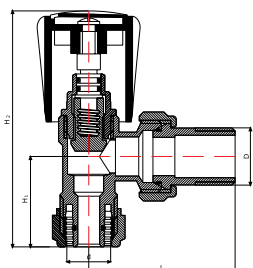

## 1/2" RADIATOR VALVE (ANGLED) (Pex Pipe Connection)

CODE	ØD (mm)	G"	H <sub>1</sub> (mm)	H <sub>2</sub> (mm)	L (mm)	Working Pressure
7800110700	DN15 d:16	1/2"	33	86.20	53.44	PN 10

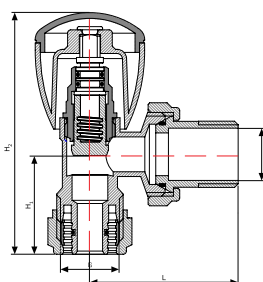

## 1/2" NEW RADIATOR VALVE (ANGLED) (Pex Pipe Connection)

CODE	ØD (mm)	G"	H <sub>1</sub> (mm)	H <sub>2</sub> (mm)	L (mm)	Working Pressure
7800110620	DN 15	1/2"	31.50	76.10	46.70	PN 10

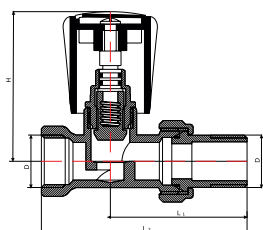

## 1/2" RADIATOR VALVE (STRAIGHT)

CODE	ØD (mm)	G"	H <sub>1</sub> (mm)	H <sub>2</sub> (mm)	L (mm)	Working Pressure
7800110800	DN 15	1/2"	59.65	54.50	82	PN 10

# Metal Systems

## 1/2" RADIATOR LOCKSHIELD VALVE

CODE	ØD (mm)	G"	H <sub>1</sub> (mm)	H <sub>2</sub> (mm)	L (mm)	Working Pressure
7800110900	DN 15	1/2"	26	50	56	PN 10

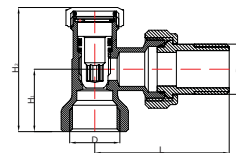

## 1/2" RADIATOR VALVE SELF SEALED (ANGLED)

CODE	ØD (mm)	G"	H <sub>1</sub> (mm)	H <sub>2</sub> (mm)	L (mm)	Working Pressure
7800110650	DN15	1/2"	23	76.15	53.44	PN 10

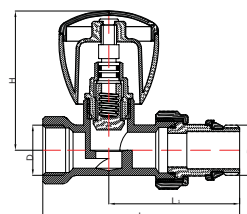

## 1/2" RADIATOR VALVE SELF SEALED (ANGLED)

(Pex Pipe Connection)

CODE	ØD (mm)	G"	H <sub>1</sub> (mm)	H <sub>2</sub> (mm)	L (mm)	Working Pressure
7800110750	DN15 d:16	1/2"	33	86.20	53.44	PN 10

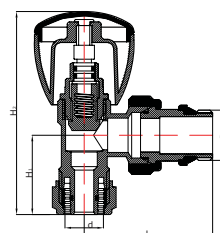

## 1/2" RADIATOR VALVE SELF SEALED (STRAIGHT)

CODE	ØD (mm)	G"	H <sub>1</sub> (mm)	H <sub>2</sub> (mm)	L (mm)	Working Pressure
7800110850	DN 15	1/2"	82	59.56	54.50	PN 10

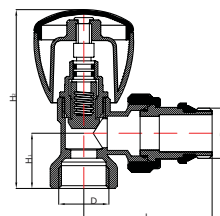

## 1/2" RADIATOR LOCKSHIELD VALVE SELF SEALED

CODE	ØD (mm)	G"	H <sub>1</sub> (mm)	H <sub>2</sub> (mm)	L (mm)	Working Pressure
7800110950	DN 15	1/2"	26	50	56	PN 10

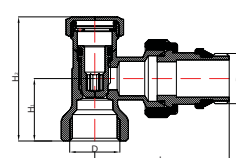

# Metal Systems

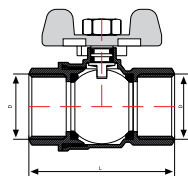

## 1" FEMALE BALL VALVE (Red or Blue Tap)

Code	ØD(mm)	G"	L(mm)	Working Pressure
<b>7800111000K Red</b>	<b>DN 25</b>	1"	74.13	PN 25
<b>7800111000M Blue</b>	<b>DN 25</b>	1"	74.13	PN 25

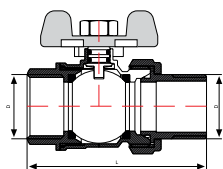

## 1" MALE BALL VALVE (Red or Blue Tap)

Code	ØD(mm)	G"	L(mm)	Working Pressure
<b>7800111100K Red</b>	<b>DN 25</b>	1"	92.73	PN 25
<b>7800111100M Blue</b>	<b>DN 25</b>	1"	92.73	PN 25

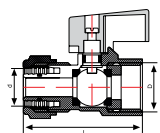

## 1/2" MINI FEMALE BALL VALVE (Pex Pipe Connection)

Code	ØD(mm)	G"	L(mm)	Working Pressure
<b>7800111000K Red</b>	<b>DN15 d:16</b>	1/2"	50.60	PN 16
<b>7800111000M Blue</b>	<b>DN15 d:16</b>	1/2"	50.60	PN 16

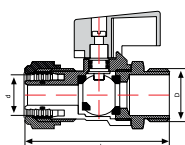

## 1/2" MINI MALE BALL VALVE (Pex Pipe Connection)

Code	ØD(mm)	G"	L(mm)	Working Pressure
<b>7800111100K Red</b>	<b>DN15 d:16</b>	1/2"	56.90	PN 16
<b>7800111100M Blue</b>	<b>DN15 d:16</b>	1/2"	56.90	PN 16

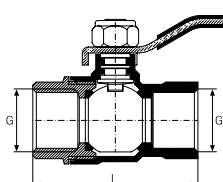

## WATER BALL VALVE (PN 10)

Code	ØD(mm)	G"	L(mm)	Working Pressure
<b>7800150001</b>	<b>DN 25</b>	1/2"	55.30	PN 10
<b>7800150002</b>	<b>DN 25</b>	3/4"	65.50	PN 10
<b>7800150003</b>	<b>DN 25</b>	1"	78.50	PN 10
<b>7800150004</b>	<b>DN 25</b>	1.1/4"	96.70	PN 10
<b>7800150005</b>	<b>DN 25</b>	1.1/2"	107.0	PN 10
<b>7800150006</b>	<b>DN 25</b>	2"	129.0	PN 10

# Metal Systems

## GAS BALL VALVE

Code	ØD(mm)	G"	L(mm)	Working Pressure
7800160001	DN 25	1/2"	55.30	PN 10
7800160002	DN 25	3/4"	65.50	PN 10
7800160003	DN 25	1"	78.50	PN 10
7800160004	DN 25	1.1/4"	96.70	PN 10
7800160005	DN 25	1.1/2"	107.0	PN 10
7800160006	DN 25	2"	129.0	PN 10

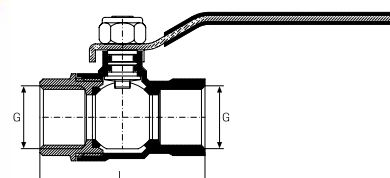

## INDUSTRIAL BALL VALVE (PN 25)

Code	ØD(mm)	G"	L(mm)	Working Pressure
7800170001	DN 25	1/2"	55.30	PN 10
7800170002	DN 25	3/4"	65.50	PN 10
7800170003	DN 25	1"	78.50	PN 10
7800170004	DN 25	1.1/4"	96.70	PN 10
7800170005	DN 25	1.1/2"	107.0	PN 10
7800170006	DN 25	2"	129.0	PN 10

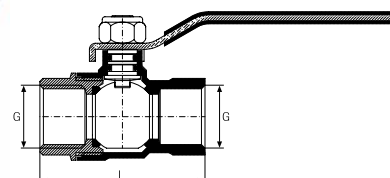

## 1/2" - 16mm PEX FEMALE SOCKET

Code	ØD(mm)	G"	L (mm)	Working Pressure
7800110200	DN:1/2"-d:16	1/2"	31	PN 10

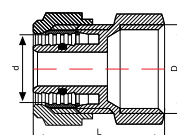

## 1/2" - 16mm PEX MALE SOCKET

Code	ØD(mm)	G"	L (mm)	Working Pressure
7800110300	DN:1/2"-d:16	1/2"	33	PN 10

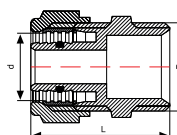

## 16mm PEX SOCKET

Code	ØD(mm)	L (mm)	Working Pressure
7800110100	d:16	43	PN 10

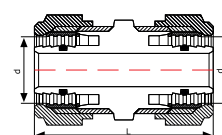

## Metal Systems

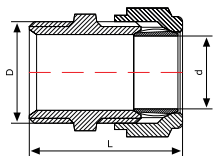

### METAL PIPE-RADIATOR CONNECTION SOCKET

Code	ØD(mm)	G"	L (mm)	Working Pressure
<b>7800110400</b>	<b>DN:1/2"-d:15</b>	1/2"	31.54	PN 10

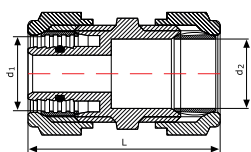

### 16mm PEX-METAL PIPE CONNECTION SOCKET

Code	ØD(mm)	L (mm)	Working Pressure
<b>7800110500</b>	<b>d<sub>1</sub>:16-d<sub>2</sub>:15</b>	41.55	PN 10

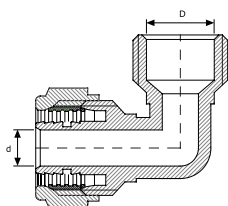

### 1/2"-16mm MALE THREADED ELBOW (Pex Pipe Connection)

Code	ØD(mm)	G"	Working Pressure
<b>7800110000</b>	<b>DN:1/2"-d:16</b>	1/2"	PN 10

### RADIATOR CONNECTION PIPE (With Socket)

Code	ØD(mm)	L(mm)
<b>7800300040</b>	<b>16</b>	400
<b>7800300060</b>	<b>16</b>	600
<b>7800300090</b>	<b>16</b>	900

### RADIATOR CONNECTION PIPE (With Elbow)

Code	ØD(mm)	L(mm)
<b>7800301040</b>	<b>16</b>	400
<b>7800301060</b>	<b>16</b>	600
<b>7800301090</b>	<b>16</b>	900

## Metal Systems

### 1" COLLEKTOR (Red-Blue)

Code	Outputs	ØD(mm)	G"	L(mm)	Working Pressure
<b>7800200200</b>	2	<b>DN 25</b>	1"	108	PN 16
<b>7800200300</b>	3	<b>DN 25</b>	1"	158	PN 16
<b>7800200400</b>	4	<b>DN 25</b>	1"	208	PN 16
<b>7800200500</b>	5	<b>DN 25</b>	1"	258	PN 16
<b>7800200600</b>	6	<b>DN 25</b>	1"	308	PN 16
<b>7800200700</b>	7	<b>DN 25</b>	1"	358	PN 16
<b>7800200800</b>	8	<b>DN 25</b>	1"	408	PN 16
<b>7800200900</b>	9	<b>DN 25</b>	1"	458	PN 16
<b>7800201000</b>	10	<b>DN 25</b>	1"	508	PN 16
<b>7800201100</b>	11	<b>DN 25</b>	1"	558	PN 16
<b>7800201200</b>	12	<b>DN 25</b>	1"	608	PN 16

Plug and Mechanical Purge are mounted on the product.

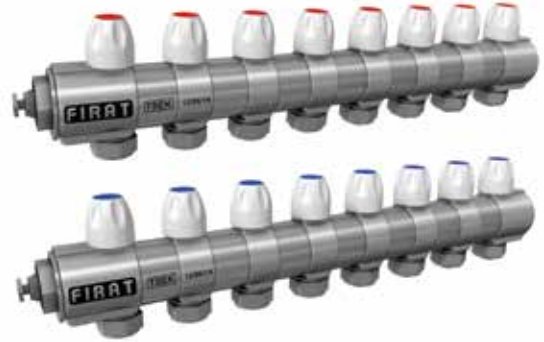

### COLLEKTOR WITH MINI BALL VALVE (Red-Blue)

Code	Outputs	ØD(mm)	G"	L(mm)	Working Pressure
<b>7800210200</b>	2	<b>DN 25</b>	1"	108	PN 16
<b>7800210300</b>	3	<b>DN 25</b>	1"	158	PN 16
<b>7800210400</b>	4	<b>DN 25</b>	1"	208	PN 16
<b>7800210500</b>	5	<b>DN 25</b>	1"	258	PN 16
<b>7800210600</b>	6	<b>DN 25</b>	1"	308	PN 16
<b>7800210700</b>	7	<b>DN 25</b>	1"	358	PN 16
<b>7800210800</b>	8	<b>DN 25</b>	1"	408	PN 16
<b>7800210900</b>	9	<b>DN 25</b>	1"	458	PN 16
<b>7800211000</b>	10	<b>DN 25</b>	1"	508	PN 16
<b>7800211100</b>	11	<b>DN 25</b>	1"	558	PN 16
<b>7800211200</b>	12	<b>DN 25</b>	1"	608	PN 16

Plug and Mechanical Purge are mounted on the product.

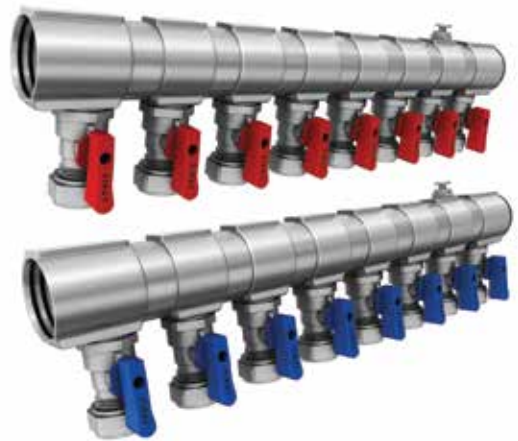

### COLLECTOR CLAMP SET

Code	ØD(mm)	L (mm)
<b>7800220000</b>	<b>DN 25</b>	300



# PPRC Pipes and Fittings

PPRC Pipe



PPRC Composite Pipe



PPRC Aluminium Foiled Pipe



## PPRC Pipes

Made of PP-R (Polypropylene Random Copolymer) Type 3 class raw material FIRAT PPRC Pipes and Fittings, which are manufactured pursuant to TS 9937, TSEN ISO 15874, DIN 8077, DIN 8078, DVGW W544 standards, can be employed in any kind of in building hot and cold water installations. PPRC Pipes and Fittings have a minimum lifespan of 50 years when used under suitable pressure and temperature values.

## COMPOSITE Pipes

1. Since Firat fiberglass added PP-R pipes have a thermal expansion coefficient close to foiled pipes, they can be used in areas where foiled pipes are utilized.
2. Welding of Firat fiberglass added PP-R pipes are similar to normal pipes. Since they do not require trimming, they provide 30% faster application compared to foiled pipes.
3. Firat fiberglass added PP-R pipes do not cause condensation and elongation in systems where heating and cooling is used together.

## Welding Specifications for PPRC Pipes

Outer Diameter (mm)	Welding Depth (mm)	Heating Period (sec)*	Welding Period (mm)	Cooling Period (minute)
20	20	20	20	20
25	25	25	25	25
32	32	32	32	32
40	40	40	40	40
50	50	50	50	50
63	63	63	63	63
75	75	75	75	75
90	90	90	90	90
110	110	110	110	110
125	125	125	125	125
160	160	160	160	160

\* If ambient temperature is below +5°C, Heating Period should be prolonged at a rate of 50%.

## PPRC, PPRC Aluminium Foiled and Composite Pipes Clamp Spacings

Temperature Difference T (°C)	Ø 20 mm			Ø 25 mm			Ø 32 mm			Ø 40 mm			Ø 50 mm			Ø 63 mm			Ø 75 mm			Ø 90 mm			Ø 110 mm		
	PPRC Pipe	Foiled Pipe	Composite Pipe	PPRC Pipe	Foiled Pipe	Composite Pipe	PPRC Pipe	Foiled Pipe	Composite Pipe	PPRC Pipe	Foiled Pipe	Composite Pipe	PPRC Pipe	Foiled Pipe	Composite Pipe	PPRC Pipe	Foiled Pipe	Composite Pipe	PPRC Pipe	Foiled Pipe	Composite Pipe	PPRC Pipe	Foiled Pipe	Composite Pipe	PPRC Pipe	Foiled Pipe	Composite Pipe
0	85	155	115	105	170	130	125	195	150	140	220	165	165	245	185	190	270	215	205	285	248	220	300	260	250	325	280
20	60	120	90	75	130	100	90	150	115	100	170	130	120	190	145	140	210	165	150	220	185	160	230	200	180	250	215
30	60	120	90	75	130	100	90	150	115	100	170	130	120	190	145	140	210	165	150	220	185	160	230	200	180	240	210
40	60	110	80	70	120	90	80	140	105	90	160	120	110	180	135	130	200	155	140	210	175	150	220	190	170	210	200
50	60	110	80	70	120	90	80	140	105	90	160	120	110	180	135	130	200	155	140	210	175	150	220	190	170	210	180
60	55	100	75	65	110	85	75	130	100	85	150	115	100	170	130	115	190	145	125	200	165	140	210	180	160	200	175
70	50	90	65	60	100	75	75	120	90	80	140	105	95	160	120	105	180	135	115	190	155	125	200	175	140	200	175



# PPRC Pipes and Fittings

## Service Lives of PPRC, PPRC Aluminium Foiled and Composite Pipes used in Water Installations

Service Lives (Year)	Operating Pressure [Bar]								
1	30.0	30.0	25.0	21.5	18.3	15.41	4.61	13.0	
5	28.1	28.1	23.9	20.2	17.0	14.31	3.61	11.9	
10	27.3	27.3	23.2	19.6	16.5	13.81	3.11	11.7	
25	26.5	26.5	22.3	18.8	15.9	13.31	2.61	10.1	
50	25.7	25.7	21.8	18.3	15.4	12.71	1.10	08.5	
<b>Temperature (°C)</b>	<b>20</b>	<b>20</b>	<b>30</b>	<b>40</b>	<b>50</b>	<b>60</b>	<b>65</b>	<b>20</b>	

## Service Lives of PPRC Pipes used in Heating Systems

Usage Period	Temperature (°C)	Service Life (Year)	Operating Pressure (Bar)
30 days/year	75	5	17.27
		10	13.79
		25	11.74
		45	10.18
		5	13.50
		10	13.80
	80	25	11.14
		42.5	9.79
		5	12.42
		10	11.87
		25	10.14
		37.5	9.18
60 days/year	85	5	11.39
		10	10.94
		25	8.86
		35	8.16
		5	14.11
		10	13.57
	75	25	11.58
		45	10.05
		5	13.12
		10	12.54
		25	10.56
		40	9.41
90 days/year	80	5	12.03
		10	11.52
		25	9.22
		35	8.48
		5	11.04
		10	9.76
	85	25	7.81
		30	7.460
		5	14.02
		10	13.38
		25	11.33
		45	9.82
90 days/year	80	5	12.90
		10	12.35
		25	10.05
		37.5	9.08
		5	11.81
		10	10.72
	85	25	8.58
		32.5	8.03
		5	10.59
		10	8.96
		25	7.17

## Do's and Don'ts in PPRC, PPRC Aluminium Foiled and Composite Pipes and Fittings

- At the end of folio stripping process, no foil particles should remain at welding distance.
- Hot air should be used in joints requiring bending process up to 30°, and 45° joints should be used in joint above 30° degrees.
- In metal fittings applications, excessive tightening should be avoided and teflon tape should be used instead of cannabis.
- Pipes should be cut by a sharp pipe clippers perpendicular to pipe axis.
- No welding should be performed on dirty pipes and fittings; pipes and fittings deformed and cracked at cutting points should not be used.
- Pipes should be protected against all kinds of blow and strike impacts.
- Conical toothed parts should not be employed at joints.
- Installation should be protected against the risk of freezing. If installation shall not be used after testing process, water inside the installation must absolutely be discharged.
- If teflons on threaders are run out or out of order, welding should not be employed (Teflon lifespan is around 2-3 household applications).
- Welding rest period should be obeyed, pipes and fittings should not be rotated during melting process.
- Measures should be taken against steam pressure accumulation in gas heater installations.
- Pipes and fittings should not be exposed to direct sunlight for long periods.
- Raw material PP-R does not contain strength stabilizer against UV rays. Maximum period of storage in an environment exposed to sunlight is six months.
- After the installation is completed, pipes and fittings should be isolated against UV rays and freezing at the sections remained outside the building.



# PPRC Pipes and Fittings

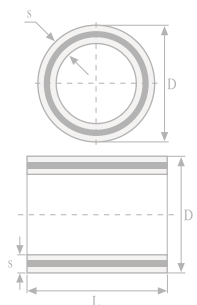
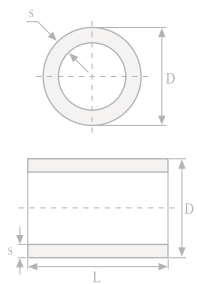
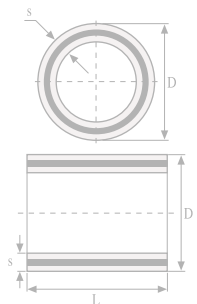
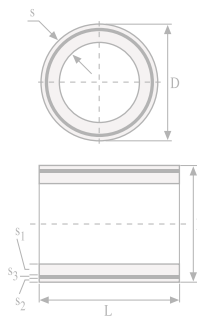
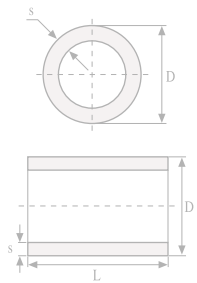

## PPRC PIPES

Code	ØD(mm)	S(mm)	L(m)
7700020020	20	3.4	4
7700020025	25	4.2	4
7700020032	32	5.4	4
7700020040	40	6.7	4
7700020050	50	8.3	4
7700020063	63	10.5	4
7700020075	75	12.5	4
7700020090	90	15	4
7700020110	110	18.3	4
7700020126	125	20.8	4
7700020127	160	26.6	4

## PPRC ALUMINIUM FOILED PIPES

Code	ØD(mm)	S(mm)	L(m)
7700020120	20	3.4	4
7700020125	25	4.2	4
7700020132	32	5.4	4
7700020140	40	6.7	4
7700020150	50	8.3	4
7700020163	63	10.5	4
7700020175	75	12.5	4

## COMPOSITE PIPES

Code	ØD(mm)	S(mm)	L(m)
7700023020	20	3.4	4
7700023025	25	4.2	4
7700023032	32	5.4	4
7700023040	40	6.7	4
7700023050	50	8.3	4
7700023063	63	10.5	4
7700023075	75	12.5	4
7700023090	90	15	4
7700023110	110	18.3	4
7700023126	125	20.8	4
7700020175	160	26.6	4

## GEDİZ PPRC PIPES

Code	ØD(mm)	S(mm)	L(m)
7700014020	20	2.8	4
7700014025	25	3.5	4
7700014032	32	4.4	4
7700014040	40	5.5	4
7700014050	50	6.9	4
7700014063	63	8.6	4
7700014075	75	10.3	4
7700014090	90	12.3	4
7700014110	110	15.1	4
7700014125	125	17.1	4
7700014160	160	21.9	4

## GEDİZ COMPOSITE PIPES

Code	ØD(mm)	S(mm)	L(m)
7700024020	20	2.8	4
7700024025	25	3.5	4
7700024032	32	4.4	4
7700024040	40	5.5	4
7700024050	50	6.9	4
7700024063	63	8.6	4
7700024075	75	10.3	4
7700024090	90	12.3	4
7700024110	110	15.1	4
7700024126	125	17.1	4
7700024160	160	21.9	4

# PPRC Pipes and Fittings

## ELBOW (90°)

Code	ØD(mm)	d	l <sub>1</sub> (mm)	Veight kg/pcs
7711000020	20	19.5	14.5	0.014
7711000025	25	24.5	16	0.023
7711000032	32	31.5	18	0.040
7711000040	40	39.4	20.5	0.068
7711000050	50	49.4	23.5	0.128
7711000063	63	62.5	27.4	0.231
7711000075	75	74.2	31	0.365
7711000090	90	89.2	35.5	0.638
7711000110	110	109	41.5	1.115
7711000125	125	123.5	46	1.989
7711000160	160	158.2	58	3.949

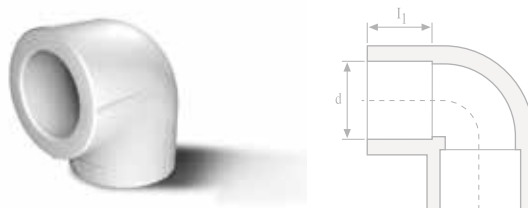

## ELBOW (45°)

Code	ØD(mm)	d	l <sub>1</sub> (mm)	Veight kg/pcs
7711001020	20	19.5	14.5	0.013
7711001025	25	24.5	16	0.015
7711001032	32	31.5	18	0.031
7711001040	40	39.4	20.5	0.050
7711001050	50	49.4	23.5	0.110
7711001063	63	62.5	27.4	0.200

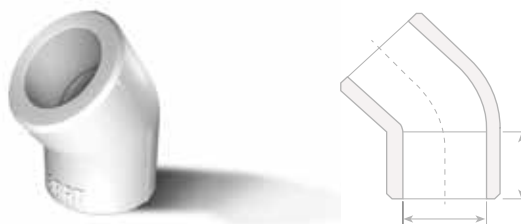

## ELBOW (90° Female-Male)

Code	ØD(mm)	d <sub>1</sub> -d <sub>2</sub> (mm)	l <sub>1</sub> -l <sub>2</sub> (mm)	Veight kg/pcs
7711002020	20	20-19.5	16-16	0.021
7711002025	25	25-24.5	16-16	0.034
7711002032	32	32-31.5	18.1-18.1	0.047

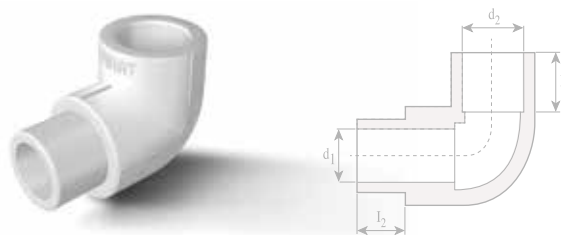

## ELBOW (45° Female-Male)

Code	ØD(mm)	d <sub>1</sub> (mm)	d <sub>2</sub> (mm)	Veight kg/pcs
7711002120	20	13.2	19.5	14.50
7711002125	25	16.6	24.5	20.90
7711002132	32	21.2	31.5	38.30



## REDUCING ELBOW (90° Female-Female)

Code	ØD(mm)	d <sub>1</sub> -d <sub>2</sub> (mm)	l <sub>1</sub> -l <sub>2</sub> (mm)	Veight kg/pcs
7724025020	20-25	19.3-24.3	16-18	0.0205
7724032025	25-32	24.3-31.3	18-20	0.0365

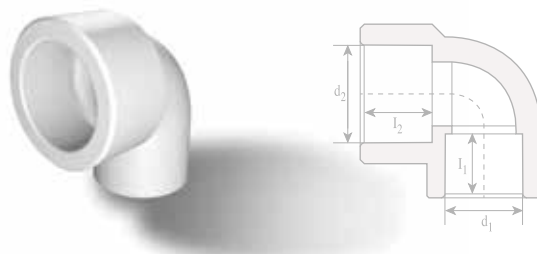

# PPRC Pipes and Fittings

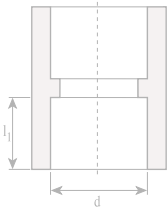

SOCKET				
Code	ØD(mm)	d	l(mm)	Weight kg/pcs
<b>772100020</b>	20	19.5	14.5	0.010
<b>772100025</b>	25	24.5	16	0.014
<b>772100032</b>	32	31.5	18	0.030
<b>772100040</b>	40	39.4	20.5	0.041
<b>772100050</b>	50	49.4	23.5	0.065
<b>772100063</b>	63	62.5	27.4	0.128
<b>772100075</b>	75	74.2	31	0.210
<b>772100090</b>	90	89.2	35.5	0.340
<b>772100110</b>	110	109	41.5	0.562
<b>772100125</b>	125	123.5	46	1.072
<b>772100160</b>	160	158.2	58	2.051

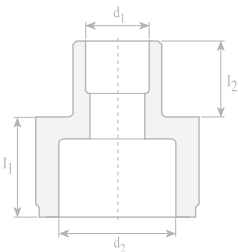

REDUCING SOCKET (Female-Male)				
Code	ØD(mm)	d1-d2 (mm)	l1-l2 (mm)	Weight kg/pcs
<b>7722025021</b>	25-20	19.5 - 25	15 - 18	0.013
<b>7722032020</b>	32-20	19.5 - 32	15 - 20	0.016
<b>7722032025</b>	32-25	24.5 - 32	18 - 20	0.009
<b>7722040020</b>	40-20	39.45 - 20	20.5 - 22.5	0.026
<b>7722040025</b>	40-25	39.45 - 25	20.5 - 22.5	0.027
<b>7722040032</b>	40-32	31.3 - 32	20.5 - 22.5	0.031
<b>7722050020</b>	50-20	19.5 - 50	16 - 24	0.037
<b>7722050025</b>	50-25	24.5 - 50	18 - 24.5	0.038
<b>7722050032</b>	50-32	31.5 - 50	20.5 - 24	0.043
<b>7722050040</b>	50-40	39.5 - 50	22 - 24	0.047
<b>7722075050</b>	75-50	49.45 - 75	30 - 37	0.125
<b>7722075063</b>	75-63	62.5 - 75	30 - 40.5	0.155
<b>7722075075</b>	90-75	74.25 - 90	31 - 35.5	0.258
<b>7722075090</b>	110-90	89.2 - 110	35.5 - 44.5	0.415
<b>7722125110</b>	125-110	108.6 - 123.5	42 - 46	0.930
<b>7722160125</b>	160-125	123.5 - 158.2	46 - 58	1.860

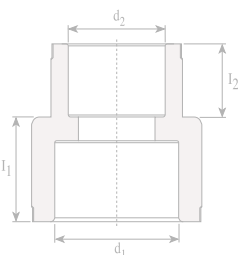

REDUCING SOCKET (Female-Female)				
Code	ØD(mm)	d1-d2 (mm)	l1-l2 (mm)	Weight kg/pcs
<b>7723025020</b>	25-20	24.5 - 19.5	18 - 15	0.021
<b>7723032025</b>	32-25	31.5 - 24.5	20 - 18	0.034
<b>7722063025</b>	63-25	24.5 - 63	20.5 - 35	0.069
<b>7722063032</b>	63-32	31.5 - 63	27.5 - 35	0.074
<b>7722063040</b>	63-40	39.4 - 63	22.5 - 35	0.076
<b>7722063050</b>	63-50	49.5 - 63	23.5 - 35	0.084

# PPRC Pipes and Fittings

## PLASTIC UNION

Code	ØD(mm)	d(mm)	d2(mm)	Veight kg/pcs
<b>7744000020</b>	20	19.3	16	0.0395
<b>7744000025</b>	25	24.3	18	0.0660
<b>7744000032</b>	32	31.3	21	0.1125

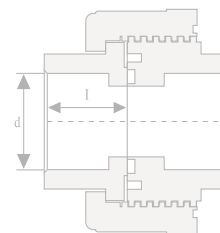

## T-PIECE

Code	ØD(mm)	d1(mm)	l1(mm)	k(mm)	Veight kg/pcs
<b>7741000020</b>	20	19.5	14.5	11	0.025
<b>7741000025</b>	25	24.5	16	13.5	0.030
<b>7741000032</b>	32	31.5	18	17	0.065
<b>7741000040</b>	40	39.4	20.5	21	0.190
<b>7741000050</b>	50	49.4	23.5	27	0.160
<b>7741000063</b>	63	62.5	27.4	32.5	0.294
<b>7741000075</b>	75	74.2	31	41	0.478
<b>7741000090</b>	90	89.2	35.5	46	0.795
<b>7741000110</b>	110	109	41.5	56	0.855
<b>7741000125</b>	125	123.5	46	65.5	2.990
<b>7741000160</b>	160	158.2	58	85	5.950

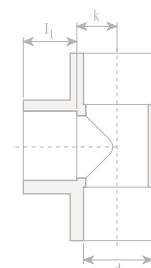

## REDUCING T-PIECE

Code	ØD(mm)	d1(mm)	d2(mm)	d2(mm)	Veight kg/pcs
<b>7742252020</b>	25-20-20	24.5	19.5	19.5	0.013
<b>7742252025</b>	25-20-25	24.5	19.5	24.5	0.016
<b>7742252520</b>	25-25-20	24.5	24.5	19.5	0.009
<b>7742322020</b>	32-20-25	31.5	19.5	19.5	0.026
<b>7742322025</b>	32-20-25	31.5	19.5	24.5	0.027
<b>7742322525</b>	32-25-25	31.5	24.5	24.5	0.031
<b>7742322032</b>	32-20-32	31.5	19.5	31.5	0.037
<b>7742322520</b>	32-25-20	31.5	24.5	19.5	0.038
<b>7742322532</b>	32-25-32	31.5	24.5	31.5	0.043
<b>7742402040</b>	40-20-40	39.4	19.5	39.4	0.047
<b>7742402540</b>	40-25-40	39.4	24.5	39.4	0.069
<b>7742403240</b>	40-32-40	39.4	31.5	39.4	0.074
<b>7742502050</b>	50-20-50	49.4	19.5	49.4	0.076
<b>7742502550</b>	50-25-50	49.4	24.5	49.4	0.084
<b>7742503250</b>	50-32-50	49.4	31.5	49.4	0.125
<b>7742504050</b>	50-40-50	49.4	39.4	49.4	0.155
<b>7742632563</b>	63-25-63	62.5	24.5	62.5	0.258
<b>7742633263</b>	63-32-63	62.5	31.5	62.5	0.415
<b>7742634063</b>	63-40-63	62.5	39.4	62.5	0.930
<b>7742635063</b>	63-50-63	62.5	49.4	62.5	1.860

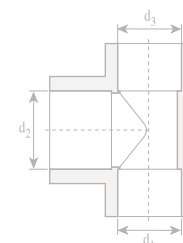

# PPRC Pipes and Fittings

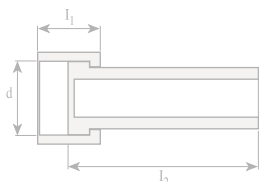

## TRANSITION NIPPLE (Female)

Code	ØD(mm)	d(mm)	l <sub>1</sub> (mm)	l <sub>2</sub> (mm)	G"	Veight kg/pcs
<b>7778025254</b>	25	24.5	20.5	60	3/4"	0.510

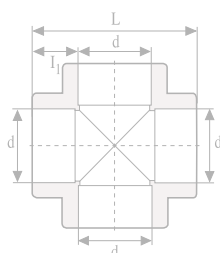

## CROSS-T

Code	ØD(mm)	d(mm)	l <sub>1</sub> (mm)	L(mm)	Veight kg/pcs
<b>7731000020</b>	20	19.5	14.5	51	0.205
<b>7731000025</b>	25	24.5	16	59	0.270
<b>7731000032</b>	32	31.5	18	70	0.394
<b>7731000040</b>	40	39.4	20.5	83	0.830

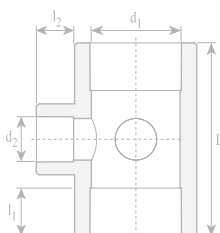

## REDUCING CORNER T-PIECE

Code	ØD(mm)	d <sub>1</sub> (mm)	d <sub>2</sub> (mm)	l <sub>1</sub> (mm)	l <sub>2</sub> (mm)	L(mm)	Veight kg/pcs
<b>7743322020</b>	32-20-20-32	31.5	19.5	18.1	14.5	69.5	0.059
<b>7743322525</b>	32-25-25-32	31.5	24.5	18.1	16	69.5	0.060
<b>7743402020</b>	40-20-20-40	39.4	19.5	20.5	14.5	82.5	0.084
<b>7743402525</b>	40-25-25-40	39.4	24.5	20.5	16	82.5	0.086

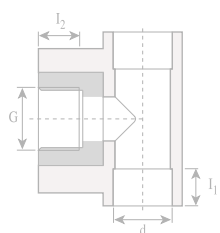

## T-ROUND (Female Threaded)

Code	ØD(mm)	d(mm)	l <sub>1</sub> (mm)	l <sub>2</sub> (mm)	G"	Veight kg/pcs
<b>7752020127</b>	20	19.5	14.5	13	1/2"	0.060
<b>7752020191</b>	20	19.5	14.5	13.5	3/4"	0.085
<b>7752025127</b>	25	24.5	16	13	1/2"	0.078
<b>7752040191</b>	25	24.5	16	13.5	3/4"	0.090
<b>7752032191</b>	32	31.5	18	13.5	3/4"	0.125

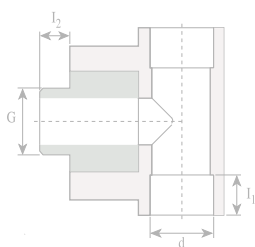

## T-ROUND (Male Threaded)

Code	ØD(mm)	d(mm)	l <sub>1</sub> (mm)	l <sub>2</sub> (mm)	G"	Veight kg/pcs
<b>7754020127</b>	20	19.5	14.5	13.5	1/2"	0.076
<b>7754025191</b>	20	14.5	16	13.5	3/4"	0.130
<b>7754020191</b>	25	19.5	14.5	13.5	3/4"	0.122
<b>7754025127</b>	25	24.5	18	13.5	1/2"	0.123

# PPRC Pipes and Fittings

## SOCKET (Female Threaded)

Code	ØD(mm)	d(mm)	I <sub>1</sub> (mm)	I <sub>2</sub> (mm)	G"	Veight kg/pcs
<b>7762020127</b>	20	19.5	14.5	13	1/2"	0.054
<b>7762020191</b>	20	19.5	14.5	13.5	3/4"	0.067
<b>7762025127</b>	25	24.5	16	13	1/2"	0.072
<b>7762040191</b>	25	24.5	16	13.5	3/4"	0.085

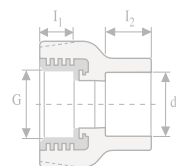

## SOCKET (Male Threaded)

Code	ØD(mm)	d(mm)	I <sub>1</sub> (mm)	I <sub>2</sub> (mm)	G"	Veight kg/pcs
<b>7764020127</b>	20	19.5	14.5	13	1/2"	0.068
<b>7764020191</b>	20	19.5	14.5	13.5	3/4"	0.123
<b>7764025127</b>	25	24.5	16	16	1/2"	0.086
<b>7764040191</b>	25	24.5	16	16	3/4"	0.101

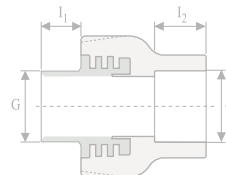

## ELBOW (Female Threaded)

Code	ØD(mm)	d(mm)	I <sub>1</sub> (mm)	I <sub>2</sub> (mm)	G"	Veight kg/pcs
<b>7772020127</b>	20	19.5	14.5	13	1/2"	0.054
<b>7772020191</b>	20	19.5	14.5	13.5	3/4"	0.078
<b>7772025127</b>	25	24.5	16	13	1/2"	0.060
<b>7772040191</b>	25	24.5	16	13.5	3/4"	0.071
<b>7772032191</b>	32	31.5	18	13.5	3/4"	0.990

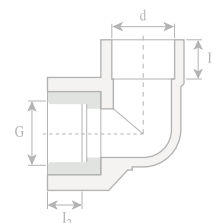

## ELBOW (Male Threaded)

Code	ØD(mm)	d(mm)	I <sub>1</sub> (mm)	I <sub>2</sub> (mm)	G"	Veight kg/pcs
<b>7774020127</b>	20	19.5	14.5	13.5	1/2"	0.068
<b>7774020191</b>	20	19.5	14.5	13.5	3/4"	0.078
<b>7774025127</b>	25	24.5	16	13.5	1/2"	0.071
<b>7774025191</b>	25	24.5	16	13.5	3/4"	0.071
<b>7774032191</b>	32	31.5	18	13.5	3/4"	0.104

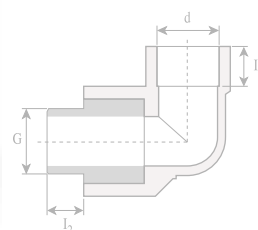

## ELBOW HEXAGONAL (Male Threaded)

Code	ØD(mm)	d(mm)	I <sub>1</sub> (mm)	I <sub>2</sub> (mm)	G"	Veight kg/pcs
<b>7772120127</b>	20	19.5	14.5	13	1/2"	0.066
<b>7772125127</b>	25	24.5	16	13	1/2"	0.082

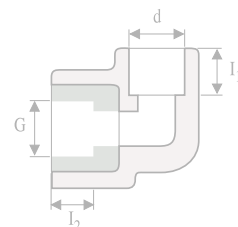

# PPRC Pipes and Fittings

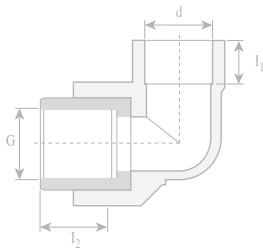

## ELBOW HEXAGONAL (Female Threaded)

Code	ØD(mm)	d(mm)	l <sub>1</sub> (mm)	l <sub>2</sub> (mm)	G"	Veight kg/pcs
<b>7771032254</b>	32	31.5	18	18	1"	0.270
<b>7771040318</b>	40	39.4	20.5	20	1.1/4"	0.291
<b>7771050381</b>	50	49.4	23.5	20	1.1/4"	0.368

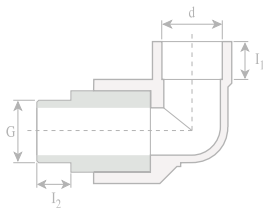

## ELBOW HEXAGONAL (Male Threaded)

Code	ØD(mm)	d(mm)	l <sub>1</sub> (mm)	l <sub>2</sub> (mm)	G"	Veight kg/pcs
<b>7773032254</b>	32	31.5	18	19	1"	0.392
<b>7773040318</b>	40	39.4	20.5	19	1.1/4"	0.361
<b>7773050381</b>	50	49.4	23.5	21.3	1.1/4"	0.458

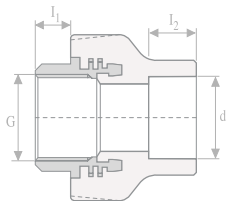

## SOCKET HEXAGONAL (Female Threaded)

Code	ØD(mm)	d(mm)	l <sub>1</sub> (mm)	l <sub>2</sub> (mm)	G"	Veight kg/pcs
<b>7761032254</b>	32	31.5	18	181	1"	0.210
<b>7761040318</b>	40	39.45	20.5	20	1.1/4"	0.400
<b>7761050381</b>	50	49.45	23.5	20	1.1/2"	0.403
<b>7761063508</b>	63	62.5	27.5	25	2"	0.661
<b>7761075635</b>	75	74.2	31	27.5	2.1/2"	0.832
<b>7761090762</b>	90	89.9	35.5	28.5	3"	1.340
<b>77611101016</b>	110	109	46	38.5	4"	2.118

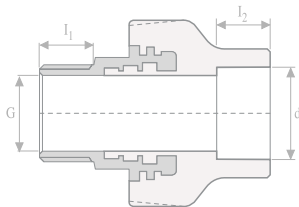

## SOCKET HEXAGONAL (Male Threaded)

Code	ØD(mm)	d(mm)	l <sub>1</sub> (mm)	l <sub>2</sub> (mm)	G"	Veight kg/pcs
<b>7763032254</b>	32	31.5	18	19	1"	0.364
<b>7763040318</b>	40	39.45	20.5	19	1.1/4"	0.664
<b>7763050381</b>	50	49.45	23.5	21.3	1.1/2"	0.690
<b>7763063508</b>	63	62.5	27.5	23	2"	0.727
<b>7763075635</b>	75	74.2	31	23	2.1/2"	0.963
<b>7763090762</b>	90	89.9	35.5	26	3"	1.440
<b>77631101016</b>	110	109	46	38.5	4"	2.578

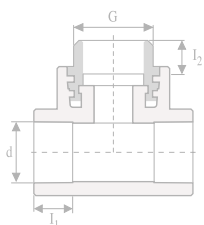

## ELBOW UNDER PLASTER (Female Threaded)

Code	ØD(mm)	d(mm)	l <sub>1</sub> (mm)	l <sub>2</sub> (mm)	G"	Veight kg/pcs
<b>7772120127</b>	20	19.5	14.5	13	1/2"	0.066
<b>7772125127</b>	25	24.5	16	13	1/2"	0.082

# PPRC Pipes and Fittings

## TRANSITION SOCKET (Female Threaded)

Code	ØD(mm)	d(mm)	L(mm)	G"	Veight kg/pcs
7765020191	20	19.5	40	1/2"	0.113
7765025191	25	24.5	45	3/4"	0.208
7765032191	32	31.5	48.5	1"	0.225
7765040191	40	39.45	52	1/4"	0.365
7765050191	50	49.4	58.1	1.1/2"	0.519
7765063191	63	62.5	67.5	2"	0.835

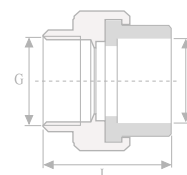

## TRANSITION SOCKET (Male Threaded)

Code	ØD(mm)	d(mm)	L(mm)	G"	Veight kg/pcs
7766020191	20	19.5	50.5	1/2"	0.204
7766025191	25	24.5	53	3/4"	0.406
7766025254	25	24.5	53	1"	0.406
7766032191	32	31.5	64	1"	0.525
7766040191	40	39.45	70.5	1/4"	0.650
7766050191	50	49.4	77.9	1.1/2"	0.625
7766063191	63	62.5	89.5	2"	0.881

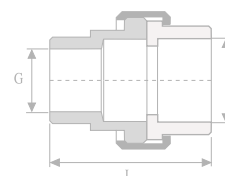

## STOP VALVE

Code	ØD(mm)	d(mm)	h(mm)	L(mm)	G"	Veight kg/pcs
7782020127	20	19.5	41.5	64.5	1/2"	0.151
7782025191	20	24.5	45	88	3/4"	0.208
7782022254	32	31.5	56.5	94	1"	0.345
7782040318	40	39.4	67.7	94.6	1"	0.348

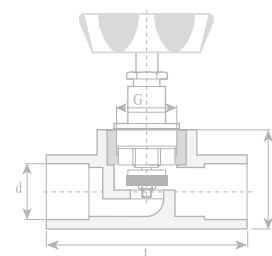

## CHROME-PLATED HIDDEN VALVE

Code	ØD(mm)	d(mm)	h(mm)	L(mm)	G"	Veight kg/pcs
7784010127	20	19.5	41.5	64.5	1/2"	0.248
7784025191	25	24.5	45	88.5	3/4"	0.296
7784032254	32	31.5	56.5	94	1"	0.427

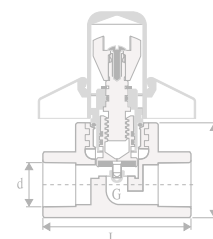

## CHROME-PLATED VALVE

Code	ØD(mm)	d(mm)	h(mm)	L(mm)	G"	Veight kg/pcs
7782010127	20	19.5	41.5	64.5	1/2"	0.433
7782015191	25	24.5	45	88	3/4"	0.464
7782012254	32	31.5	56.5	94	1"	0.600

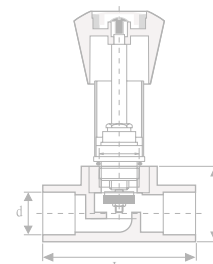

# PPRC Pipes and Fittings

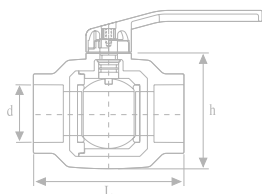

## BALL VALVE (Metal Handle)

Code	ØD(mm)	d(mm)	h(mm)	L(mm)	G"	Veight kg/pcs
<b>7783020127</b>	20	19.5	50	65	1/2"	0.1599
<b>7783025191</b>	25	24.5	55	73	3/4"	0.1848
<b>7783032254</b>	32	31.5	65	77.5	1"	0.2360
<b>7783040318</b>	40	39.5	71	91.5	1.1/4"	0.3364
<b>7783050381</b>	50	49.4	88	117	1.1/2"	0.5646
<b>7783063508</b>	63	62.5	110	136	2"	0.7927
<b>7783075635</b>	75	74.7	130.75	155.5	2.1/2"	1.3086

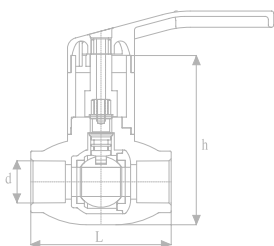

## BALL VALVE (Metal Handle & Long Type)

Code	ØD(mm)	d(mm)	h(mm)	L(mm)	G"	Veight kg/pcs
<b>7783520127</b>	20	31.5	79	87.5	1/2"	0.1723
<b>7783525191</b>	25	39.5	84.5	103.5	3/4"	0.2082

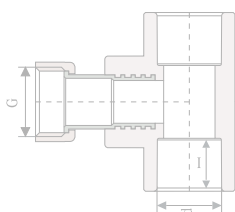

## T - WITH LOOSE NUT

Code	ØD(mm)	d(mm)	L(mm)	G"	Veight kg/pcs
<b>7776020127</b>	20	19.5	16	1/2"	0.260
<b>7776025191</b>	25	24.5	18	3/4"	0.360
<b>7776032254</b>	32	31.5	20	1"	0.765

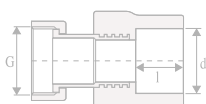

## SOCKET WITH LOOSE NUT

Code	ØD(mm)	d(mm)	L(mm)	G"	Veight kg/pcs
<b>7775020127</b>	20	19.5	16	1/2"	0.096
<b>7775025191</b>	25	24.5	18	3/4"	0.185
<b>7775032254</b>	32	31.5	20	1"	0.345

# PPRC Pipes and Fittings

## ELBOW WITH LOOSE NUT

Code	ØD(mm)	d(mm)	l(mm)	G"	Veight kg/pcs
<b>7777020127</b>	20	19.5	16	1/2"	0.250
<b>7777025191</b>	25	24.5	18	3/4"	0.285
<b>7777032254</b>	32	31.3	20	1"	0.490

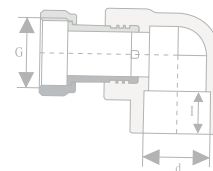

## Y - FILTER

Code	ØD(mm)	d1-d2(mm)	l(mm)	G"	Veight kg/pcs
<b>7781020127</b>	20	19.5 - 20	16	1/2"	0.400
<b>7781025191</b>	25	24.5 - 25	18	3/4"	0.745
<b>7780532254</b>	32	31.5 - 32	20	1"	0.818

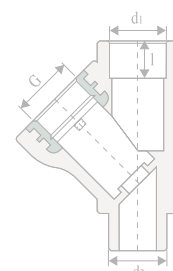

## RADIATOR VALVE (Angled)

Code	ØD(mm)	d(mm)	l(mm)	G"	Veight kg/pcs
<b>7791020127</b>	20	19.5	14.5	1/2"	0.227
<b>7791025191</b>	25	24.5	18	3/4"	0.243

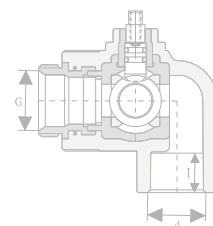

## RADIATOR VALVE (Angled)

Code	ØD(mm)	d(mm)	l(mm)	G"	Veight kg/pcs
<b>7792020127</b>	20	19.5	14.5	1/2"	0.239
<b>7792025191</b>	25	24.5	18	3/4"	0.277

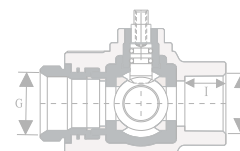

## ARMATURE STABILIZER

Code	ØD(mm)	d(mm)	B(mm)	A(mm)	L(mm)	G"	Veight kg/pcs
<b>7734000000</b>	26	48.5	50	50	260	1/2"	0.635

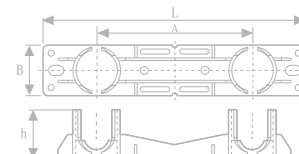

## PPRC Pipes and Fittings

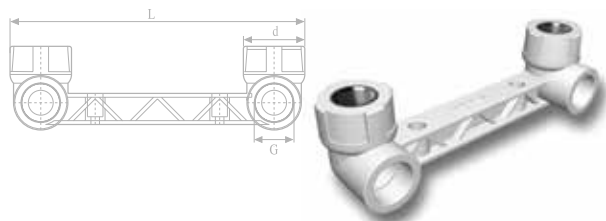

### ARMATURE CONNECTOR

CODE	ØD(mm)	d(mm)	g(mm)	l(mm)	G"	Veight kg/pcs
<b>7780020128</b>	20	30.0	19.5	189	1/2"	0.135
<b>7780025127</b>	25	39.5	24.5	190	1/2"	0.150

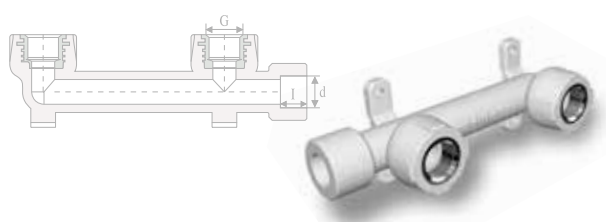

### ARMATURE CONNECTOR FOR BIDET

CODE	ØD(mm)	d(mm)	l(mm)	G"	Veight kg/pcs
<b>7780120127</b>	20	19.5	16	1/2"	0.100
<b>7780125127</b>	25	24.5	18	1/2"	0.171

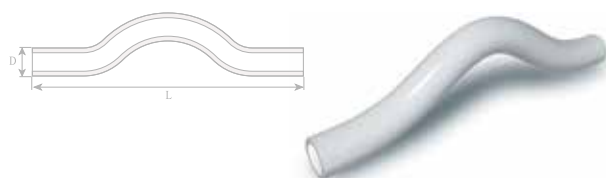

### CURVED BRIDGE

CODE	ØD(mm)	L(mm)	Veight kg/pcs
<b>7700120020</b>	20	280	0.048
<b>7700120025</b>	25	280	0.079
<b>7700120032</b>	32	310	0.138
<b>7700120040</b>	40	310	0.208

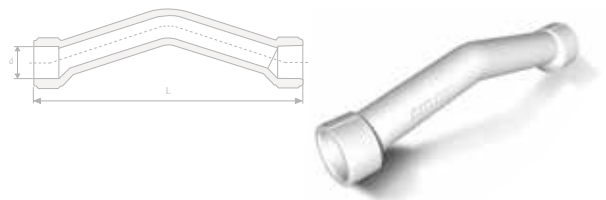

### BRIDGE WITH SOCKET

CODE	ØD(mm)	d(mm)	L(mm)	Veight kg/pcs
<b>7700130020</b>	20	19.8	160	0.035
<b>7700130025</b>	25	24.8	200	0.065

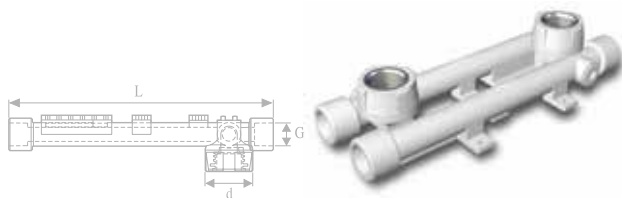

### ADJUSTABLE ARMATURE CONNECTOR

Code	ØD(mm)	d(mm)	L(mm)	G"	Veight kg/pcs
<b>7780020127</b>	20	19.5	225	1/2"	0.220

# PPRC Pipes and Fittings

## HALF CURVE WITH SOCKET

CODE	ØD(mm)	d(mm)	L(mm)	Veight kg/pcs
<b>7700140020</b>	20	19.8	120.81	0.028
<b>7700140025</b>	25	24.8	157.05	0.049

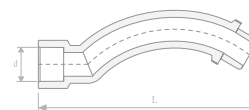

## SHORT BRIDGE

CODE	ØD(mm)	d(mm)	L(mm)	Veight kg/pcs
<b>7700150020</b>	20	19.8	85	0.027
<b>7700150025</b>	25	24.8	97.5	0.044
<b>7700150032</b>	32	31.5	130	0.096

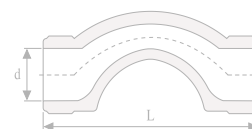

## CURVED ELBOW (Female)

CODE	ØD(mm)	d1(mm)	L(mm)	Veight kg/pcs
<b>7711003120</b>	20	19.5	14.5	0.024
<b>7711003125</b>	25	24.5	16	0.043

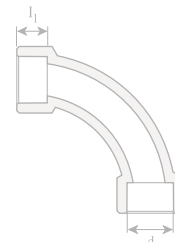

## CURVED ELBOW (Male)

CODE	ØD(mm)	d1(mm)	d2(mm)	l1(mm)	l2(mm)	Veight kg/pcs
<b>7711003120</b>	20	19.5	20	14.5	14.5	0.022
<b>7711003125</b>	25	24.5	25	16	16	0.040

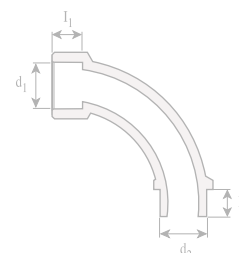

## PLUG

CODE	ØD(mm)	L(mm)	AA(mm)	G"	Veight kg/pcs
<b>7733000027</b>	20	29	22	1/2"	0.007
<b>7733000033</b>	25	23	24	3/4"	0.008

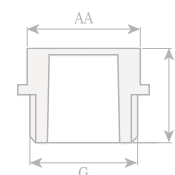

# PPRC Pipes and Fittings

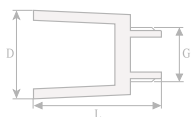

## LONG PLUG

CODE	ØD(mm)	d(mm)	L(mm)	G"	Veight kg/pcs
<b>7732020020</b>	32.5	49.5	49.5	1/2"	0.013

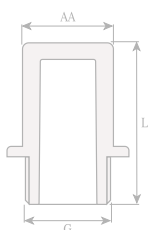

## LONG PLUG (Type 2)

CODE	ØD(mm)	L(mm)	AA(mm)	G"	Veight kg/pcs
<b>7732010020</b>	20	39	22	1/2"	0.018

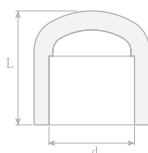

## END CAP

CODE	ØD(mm)	d(mm)	l <sub>1</sub> (mm)	L(mm)	Veight kg/pcs
<b>7731000020</b>	20	19.5	14.5	25.8	0.013
<b>7731000025</b>	25	24.5	16	31.5	0.015
<b>7731000032</b>	32	31.5	18	36	0.026
<b>7731000040</b>	40	39.4	20.5	42	0.034
<b>7731000050</b>	50	49.4	23.5	47	0.048
<b>7731000063</b>	63	62.5	27.5	56.4	0.090
<b>7731000075</b>	75	74.2	31	70	0.190
<b>7731000090</b>	90	89.2	35.5	80	0.274
<b>7731000110</b>	110	109	41	9	0.600
<b>7731000125</b>	125	123.5	46	105	1.004
<b>7731000160</b>	160	158.2	58	131	1.817

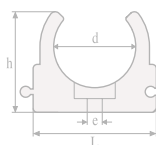

## CLAMP

CODE	ØD(mm)	d(mm)	e(mm)	h(mm)	L(mm)	Veight kg/pcs
<b>7733000020</b>	20	19	5.5	27.3	30	0.005
<b>7733000025</b>	25	24	5.5	31.5	36	0.006
<b>7733000032</b>	32	30	5.5	36.7	45	0.009
<b>7733000040</b>	40	39	5.5	44.7	54	0.010

## PPRC Pipes and Fittings

### DOUBLE CLAMP

Code	ØD(mm)	d(mm)	h(mm)	L(mm)	Veight kg/pcs
<b>7733000021</b>	20	19.8	29.6	64.4	0.013
<b>7733000026</b>	25	24.8	30.7	78.7	0.014
<b>7733000034</b>	32	31.5	37.5	87.5	0.016

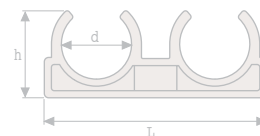

### DOUBLE CLAMP (For Aluminium Foiled Pipes)

CODE	ØD(mm)	d(mm)	h(mm)	L(mm)	Veight kg/pcs
<b>7733000027</b>	25	24.8	30.7	78.7	0.014
<b>7733000033</b>	32	31.5	37.5	87.5	0.016

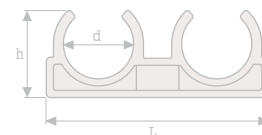

### FOLYOMATİK

CODE	ØD(mm)
<b>8795063020</b>	20
<b>8795063025</b>	25
<b>8795063032</b>	32



### BOILER SET

CODE	Box
<b>7680000100</b>	12 Box / Parcel



# Dublex Waste Water Pipes and Fittings

Firat Dublex PVC waste water pipes and fittings are used in the villas and multi-storey buildings, hospitals, schools, hotels, industrial and sport buildings etc. as they are environment-friendly and cost-effective, maintaining its physical structure up to 60°C, suitable for long-term use, allowing safe and ideal discharge of surface and subsurface waste water.

FIRAT Dublex PVC waste water pipes and fittings are manufactured in the wall thicknesses of the application class BD specified as per the quality standards TS 275-1 EN 1329-1. Thanks to their smooth internal and external surfaces, they do not allow formation of deposit and debris or growth of bacteria and smell.

Manufactured from rigid PVC raw material, FIRAT Dublex PVC waste water pipes and fittings are of flame-retardant construction material class B1 as defined by the DIN 4102 and National Fire Regulations. FIRAT Dublex PVC-based waste water and fittings are, therefore, fireproof in case of possible fire cases (PP-based materials are inflammable and combustible), preventing spread of fire between the floors. For this reason, they are especially recommended for the multi-storey buildings.

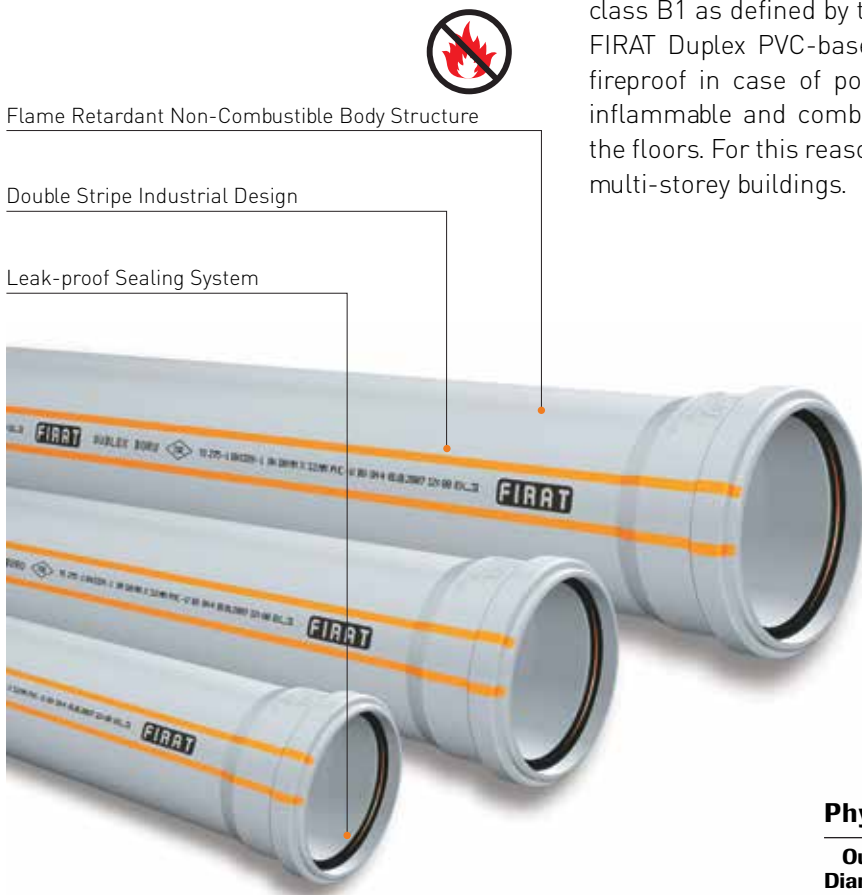

With a wide range of alternatives in sizes, e.g., 50 - 315 mm diameter and 150 - 6000 mm length, FIRAT Dublex waste water pipes and fittings satisfy all kinds of requirements for discharge of waste water discharge. Dublex PVC waste water fittings never allow leakage due to the sealing bearings which are single-cheek, spiked and fully compatible. As they are easy to install and replace, the discharge system is installed quickly and does not require laborious operations such as cutting, bending and adhering.

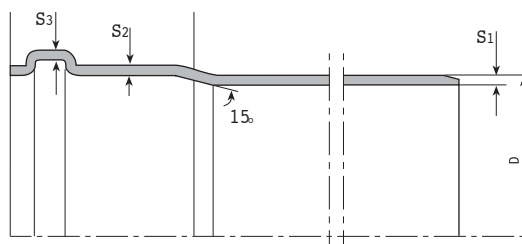

### Physical Specifications of Dublex Pipes

Outer Diameter (mm)	S1 (mm)	S2 (mm)	S3 (mm)	LB	Weight (kg/m)
50	3.0	2.9	2.4	39.3	0.777
75	3.0	2.9	2.4	46.1	1.180
110	3.2	2.9	2.4	56.9	1.880
125	3.2	2.9	2.4	62.8	2.014
160	4.0	3.6	3.0	75.8	3.046
200	4.9	4.4	3.7	89.4	5.240
250	6.2	5.6	4.7	112.6	8.470
315	7.7	6.9	5.8	135.4	13.420

# Dublex Waste Water Pipes and Fittings

## General Features

- PVC-U Pipes and fittings are used for waste water discharge in buildings.
- They are manufactured in diameters between Ø 50-315 mm as defined in TS 275-1 EN 1329-1 standard and in various lengths from 15 cm to 6 m with seals.
- The most important feature of PVC-U Pipes and fittings is their non-combustibility. With this feature, spread of a fire between floors in the building is prevented.
- FIRAT Duplex PVC-U Pipes are manufactured as BD class (with thick wall) as defined in TS 275-1 EN 1329-1 standard.
- BD application field code defines applications, including surface and under plaster mounted systems, until building sewage system connection
- PVC-U Pipes and fittings preserve their physical structure under continuous operating temperature up to 60°C.
- Cornered seal groove and special seal ensures 100% leak-proof performance in leakage test (0.5 bar 15 min).



Collar interval in the installation of PVC Dublex Pipes and Fittings should be 1 m.



### Dublex PVC Pipe Seal

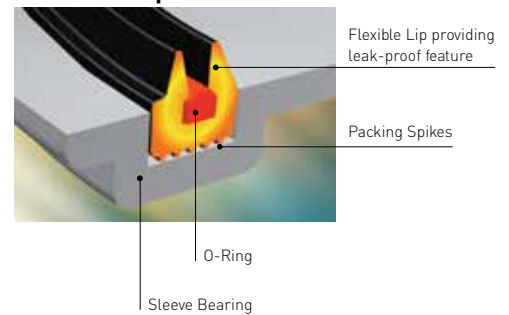

# Dublex Waste Water Pipes and Fittings

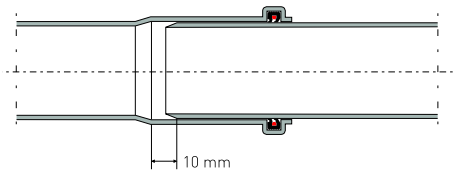
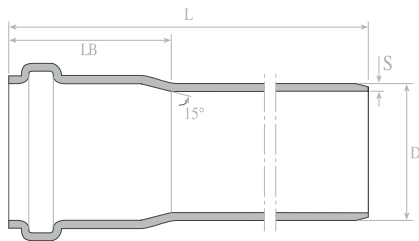

## DUBLEX WASTE WATER PIPES

CODE	ØD(mm)	Length L (mm)
7030050015	50	150
7030050025	50	250
7030050050	50	500
7030050100	50	1000
7030050200	50	2000
7030050300	50	3000
7030050600	50	6000
7030070015	75	150
7030070025	75	250
7030070050	75	500
7030070100	75	1000
7030070200	75	2000
7030070300	75	3000
7030070600	75	6000
7030100015	110	150
7030100025	110	250
7030100050	110	500
7030100100	110	1000
7030100200	110	2000
7030100300	110	3000
7030100600	110	6000
7030125015	125	150
7030125025	125	250
7030125050	125	500
7030125100	125	1000
7030125200	125	2000
7030125300	125	3000
7030125600	125	6000
7030150015	160	150
7030150025	160	250
7030150050	160	500
7030150100	160	1000
7030150200	160	2000
7030150300	160	3000
7030150600	160	6000
7030200015	200	150
7030200025	200	250
7030200050	200	500
7030200100	200	1000
7030200200	200	2000
7030200300	200	3000
7030200600	200	6000
7030250015	250	150
7030250025	250	250
7030250050	250	500
7030250100	250	1000
7030250200	250	2000
7030250300	250	3000
7030250600	250	6000
7030315050	315	500
7030315100	315	1000
7030315200	315	2000
7030315300	315	3000
7030315600	315	6000

# Dublex Waste Water Pipes and Fittings

## ELBOW (45°)

CODE	ØD(mm)	d1(mm)	d2(mm)	S1(mm)	S2(mm)	S3(mm)
7011050087	50	50	50.3	3.0	2.7	2.3
7011075087	75	75	75.4	3.0	2.7	2.3
7011100087	110	110.4	110.4	3.2	2.9	2.4
7011125087	125	125.4	125.5	3.2	2.9	2.4
7011150087	160	160.5	160.5	4.0	3.6	3.0
7011200087	200	200.6	200.6	4.9	4.4	3.7
7011250087	250	250.6	250.6	6.2	5.6	4.7

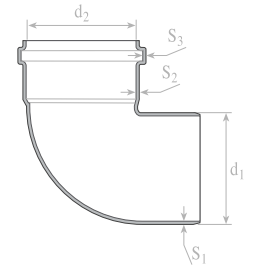

## ELBOW (87°)

CODE	ØD(mm)	d1(mm)	d2(mm)	S1(mm)	S2(mm)	S3(mm)
7011050045	50	50	50.3	3.0	2.7	2.3
7011075045	75	75	75.4	3.0	2.7	2.3
7011100045	110	110	110.4	3.2	2.9	2.4
7011125045	125	125	125.5	3.2	2.9	2.4
7011160045	160	150	160.5	4.0	3.6	3.0
7011200045	200	200	200.6	4.9	4.4	3.7
7011250045	250	250	250.6	6.2	5.6	4.7

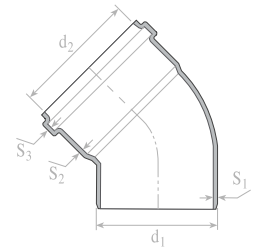

## T-PIECE

CODE	ØD(mm)	d1(mm)	d2(mm)	d3(mm)	S1(mm)	S2(mm)	S3(mm)
7014050050	50-50	50	50.3	50.3	3.0	2.7	2.3
7014070050	75-50	75	75.4	75.4	3.0	2.7	2.3
7014070070	75-75	75	75.4	75.4	3.0	2.7	2.3
7014100050	110-50	110	110	110.4	3.2	2.9	2.4
7014100070	110-75	110	110	110.4	3.2	2.9	2.4
7014100100	110-110	110	110	110.4	3.2	2.9	2.4
70K0412505	125-50	125	125	125.5	3.2	2.9	2.4
70K0412507	125-75	125	125	125.5	3.2	2.9	2.4
7014125100	125-110	125	125	125.5	3.2	2.9	2.4
7014125125	125-125	125	125	125.5	3.2	2.9	2.4
70K0415005	160-50	160	160	160.5	4.0	3.6	3.0
70K0415007	160-75	160	160	160.5	4.0	3.6	3.0
7014150100	160-110	160	160	160.5	4.0	3.6	3.0
7014150125	160-125	160	160	160.5	4.0	3.6	3.0
7014150150	160-160	160	160	160.5	4.0	3.6	3.0
70K0420010	200-110	200	200	200.7	4.9	4.4	3.7
70K0420012	200-125	200	200	200.7	4.9	4.4	3.7
70K0420015	200-160	200	200	200.7	4.9	4.4	3.7
7014200200	200-200	200	200	200.7	4.9	4.4	3.7
70K0425015	250-160	250	250	250.6	6.2	5.6	4.7
70K0425020	250-200	250	250	250.6	6.2	5.6	4.7
7014250250	250-250	250	250	250.6	6.2	5.6	4.7

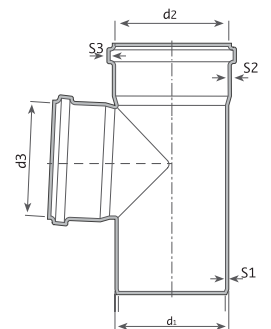

# Dublex Waste Water Pipes and Fittings

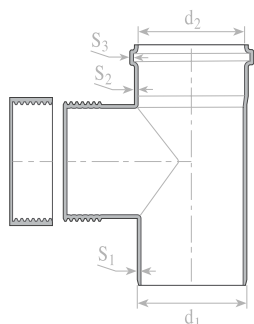

## ACCESS T-PIECE

CODE	ØD(mm)	d2(mm)	S1(mm)	S2(mm)	S3(mm)
<b>7016001070</b>	75	50	50.3	3.0	2.7
<b>7016001100</b>	110	75	75.4	3.0	2.7
<b>7016001125</b>	125	110.4	110.4	3.2	2.9
<b>7016001150</b>	160	125.4	125.5	3.2	2.9
<b>7016001200</b>	200	160.5	160.5	4.0	3.6
<b>70K0625000</b>	250	200.6	200.6	4.9	4.4
<b>70K0631500</b>	315	250.6	250.6	6.2	5.6

K: Confection Production

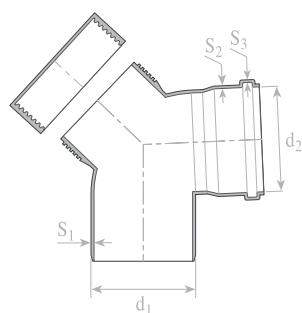

## CLEAN OUT ELBOW

CODE	ØD(mm)	d2(mm)	S1(mm)	S2(mm)	S3(mm)
<b>7016001110</b>	110	110.4	3.2	2.9	2.9

## SINGLE BRANCH (45°)

CODE	ØD(mm)	d1(mm)	d2(mm)	d3(mm)	S1(mm)	S2(mm)	S3(mm)
<b>7013050050</b>	50-50	50	50.3	50.3	3.0	2.7	2.3
<b>7013070050</b>	75-50	75	75.4	50.3	3.0	2.7	2.3
<b>7013070070</b>	75-75	75	75.4	75.4	3.0	2.7	2.3
<b>7013100050</b>	110-50	110	110.4	50.3	3.2	2.9	2.4
<b>7013100070</b>	110-75	110	110.4	75.4	3.2	2.9	2.4
<b>7013100100</b>	110-110	110	110.4	110.4	3.2	2.9	2.4
<b>7013125050</b>	125-50	125	125.5	50.3	3.2	2.9	2.4
<b>7013125070</b>	125-75	125	125.5	75.4	3.2	2.9	2.4
<b>7013125100</b>	125-110	125	125.5	110.4	3.2	2.9	2.4
<b>7013125125</b>	125-125	125	125.5	125.5	3.2	2.9	2.4
<b>70K0315005</b>	160-50	160	160.6	50.4	4.0	3.6	3.0
<b>70K0315007</b>	160-75	160	160.6	75.4	4.0	3.6	3.0
<b>7013150100</b>	160-110	160	160.6	110.4	4.0	3.6	3.0
<b>7013150125</b>	160-125	160	160.5	125.5	4.0	3.6	3.0
<b>7013150150</b>	160-160	160	160.5	160.5	4.0	3.6	3.0
<b>7013200100</b>	200-110	200	200.7	110.5	4.9	4.4	3.7
<b>70K0320012</b>	200-125	200	200.7	125.5	4.9	4.4	3.7
<b>7013200150</b>	200-160	200	200.7	160.6	4.9	4.4	3.7
<b>7013200200</b>	200-200	200	200.7	200.7	4.9	4.4	3.7
<b>70K0325010</b>	250-100	250	200.7	110.5	6.2	5.6	4.7
<b>70K0325012</b>	250-125	250	250.6	125.5	6.2	5.6	4.7
<b>70K0325015</b>	250-150	250	250.6	160.6	6.2	5.6	4.7
<b>70K0325020</b>	250-200	250	250.6	200.7	6.2	5.6	4.7
<b>7013250250</b>	250-250	250	250.6	250.6	6.2	5.6	4.7

K: Confection Production

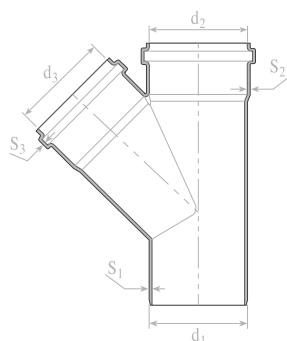

# Dublex Waste Water Pipes and Fittings

## REDUCER

CODE	ØD(mm)	d1(mm)	d2(mm)	S1(mm)	S2(mm)	S3(mm)
7012070050	75-50	75	50.3	3.3	2.7	2.3
7012100050	110-50	110	50.3	3.2	2.9	2.4
7012100070	110-75	110	75.4	3.2	2.9	2.4
7012125070	125-75	125	75.4	3.2	2.9	2.4
7012125100	125-110	125	110.4	3.2	2.9	2.4
7012150100	160-110	160	110.4	4.0	3.6	3.0
7012150125	160-125	160	125.5	4.0	3.6	3.0
7012200100	200-110	200	110.4	4.9	4.4	3.7
70K0220012	200-125	200	125.5	4.9	4.4	3.7
7012200150	200-160	200	160.5	4.9	4.4	3.7
7012250200	250-200	250	200.6	6.2	4.4	3.7

K: Confection Production

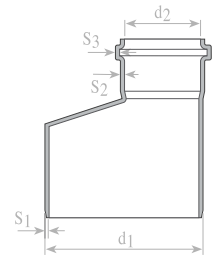

## CROSS-T

CODE	ØD(mm)	d-d1(mm)	d2-d3(mm)	S1(mm)	S2(mm)	S3(mm)
7014500100	110	110	110.4	3.2	2.9	2.4

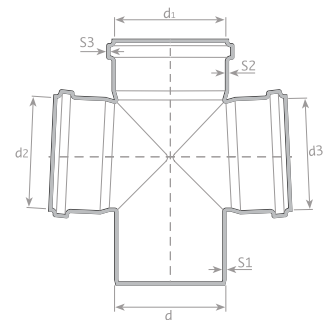

## DOUBLE BRANCH (45°-45°)

CODE	ØD(mm)	d1(mm)	d2(mm)	d3(mm)	S1(mm)	S2(mm)	S3(mm)
7015050050	50-50	50	50.3	50.3	3.0	2.7	2.3
7015070050	75-50	75	75.4	50.3	3.0	2.7	2.3
7015070070	75-75	75	75.4	75.4	3.0	2.7	2.3
7015100050	110-50	110	110.4	50.3	3.2	2.9	2.4
7015100070	110-75	110	110.4	75.4	3.2	2.9	2.4
7015100100	110-110	110	110.4	110.4	3.2	2.9	2.4
70K0512505	125-50	125	125.5	50.3	3.2	2.9	2.4
70K0512507	125-75	125	125.5	75.4	3.2	2.9	2.4
7015125100	125-110	125	125.5	110.4	3.2	2.9	2.4
70K0512512	125-125	125	125.5	125.5	3.2	2.9	2.4
70K0515005	160-50	160	160.6	50.4	4.0	3.6	3.0
70K0515007	160-75	160	160.6	75.4	4.0	3.6	3.0
70K0515010	160-110	160	160.6	110.4	4.0	3.6	3.0
70K0515012	160-125	160	160.5	125.5	4.0	3.6	3.0
70K0515015	160-160	160	160.5	160.5	4.0	3.6	3.0
70K0520010	200-110	200	200.7	110.5	4.9	4.4	3.7
70K0520012	200-125	200	200.7	125.5	4.9	4.4	3.7
70K0520015	200-160	200	200.7	160.6	4.9	4.4	3.7
70K0520020	200-200	200	200.6	200.6	4.9	4.4	3.7
70K0525025	250-250	250	250.6	250.6	6.2	5.6	4.7

K: Confection Production

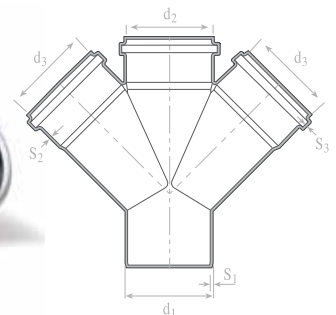

# Dublex Waste Water Pipes and Fittings

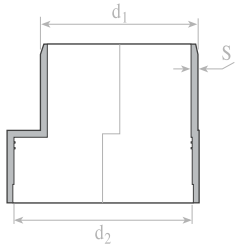

## WC CONNECTOR

CODE	$\text{ØD}$ (mm)	$d_1$ (mm)	$d_2$ (mm)	$S_3$ (mm)
<b>7066002100</b>	110	110	131.0	3.2

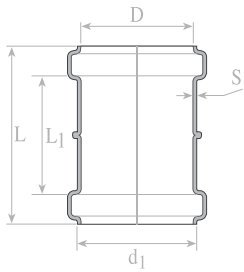

## SLIDING SOCKET

CODE	$\text{ØD}$ (mm)	$D$ (mm)	$d_1$ (mm)	$S$ (mm)	$L$ (mm)	$L_1$ (mm)
<b>7066007050</b>	50	50.3	59.6	3.0	84	58.4
<b>7066007070</b>	75	75.4	84.5	3.0	96	70.4
<b>7066007100</b>	110	110.4	120.6	3.2	130	98.8
<b>7066007125</b>	125	125.4	137.5	3.2	160	112.4
<b>7066007150</b>	160	160.5	174.3	4.0	170	125.0

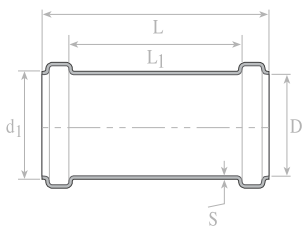

## SOCKET

CODE	$\text{ØD}$ (mm)	$D$ (mm)	$d_1$ (mm)	$S$ (mm)	$L$ (mm)	$L_1$ (mm)
<b>7016007125</b>	125	125.4	137.5	3.2	480	420
<b>7016007160</b>	160	160.5	174.3	4.0	480	420
<b>7016007200</b>	200	200.6	216.7	4.9	760	700

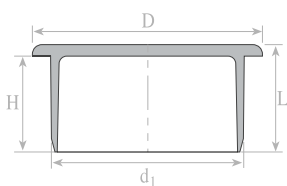

## PLUG

CODE	$\text{ØD}$ (mm)	$D$ (mm)	$d_1$ (mm)	$L$ (mm)	$H$ (mm)
<b>7016004050</b>	50	60	50	28	25
<b>7016004070</b>	75	85	75	34	30
<b>7016004100</b>	110	120	110	38	34
<b>7016004125</b>	125	138	125	40	45
<b>7016004150</b>	160	173	160	60	55
<b>7016004200</b>	200	214	200	71	65

## Dublex Waste Water Pipes and Fittings

### S SIPHON

CODE	ØD (mm)	d1 (mm)	d2 (mm)	a (mm)	b (mm)	S (mm)
7016002145	75/45°	75	97	150	202	3.0
7016002175	75/87°	75	97	150	195	3.0
7016002100	100	110	140	212	290	3.2
7016002145	110/45°	110	140	212	263	3.2

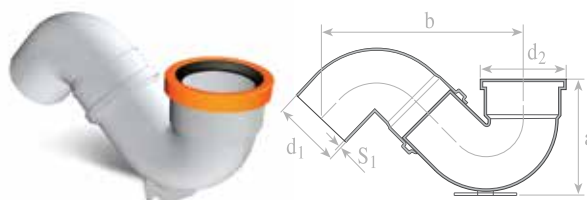

### S SIPHON WITH MUFF

CODE	ØD (mm)	d1 (mm)	d2 (mm)	a (mm)	b (mm)	S (mm)
7017000100	110	110	126	176	167	3.2
7017000145	110/45°	110	126	178	268	3.2

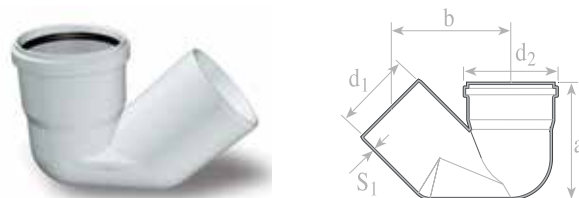

### AIR HOLE PIPE

CODE	ØD (mm)	d1 (mm)	S (mm)
70K0707000	75	75	3.2
70K0710000	110	110	4.0
			4.9

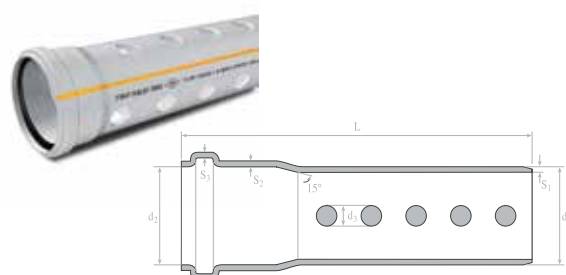

### REPAIR SOCKET

CODE	ØD (mm)	D (mm)	d1 (mm)	S (mm)	L (mm)	L1 (mm)
7016007125	125	125.4	137.5	3.2	480	420
7016007160	160	160.5	174.3	4.0	480	420
7016007200	200	200.6	216.7	4.9	760	700

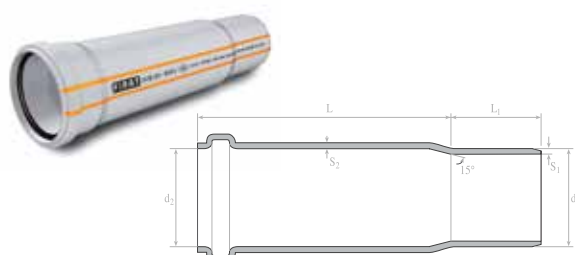

## Dublex Waste Water Pipes and Fittings

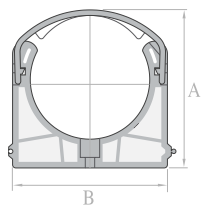

### BRACELETS

CODE	ØD <sub>(mm)</sub>	A <sub>(mm)</sub>	B <sub>(mm)</sub>
<b>7016005050</b>	50	78.30	57.60
<b>7016005070</b>	75	118.20	83.60
<b>7016005100</b>	110	152.55	120.00
<b>7016005125</b>	125	159.50	167.65
<b>7016005150</b>	160	207.60	207.45



### ADAPTING SEAL

CODE	ØD <sub>(mm)</sub>
<b>7066005050</b>	50

## Dublex Waste Water Pipes and Fittings

### WASTE WATER SEAL

CODE	ØD(mm)
2001001050	50
2001001070	75
2001001100	110
2001001125	125
2001001150	160
2001001200	200
2001001250	250



### WASTE WATER O'RING SEAL

CODE	ØD(mm)
7800090050	50
7800090070	75
7800090100	110



## New Residence Silent Power Pipes and Fittings

### General Definition

Fluids passing through the pipe at different flow velocities cause vibrations while hitting the pipe walls and obstacles in the pipe and make sounds that cause disturbances in living spaces.

Modern developments in the construction sector have accelerated housing delivery times. Construction companies needed quieter piping to reduce the additional labour costs and time costs for installation of insulation.

### Silent Pipe Usage Areas

Due to its characteristics of being ecological, economic and soundproof Residence Pipe and Fittings is a preferable choice to be used in villas and multi-storey residences, hospitals, schools, hotels and industrial or sportive structures, etc. Silent pipes ensure for the sewage from the foundations and interior structures of buildings to be drained in an ideal and safe way without any leakage for long terms use (50 years).

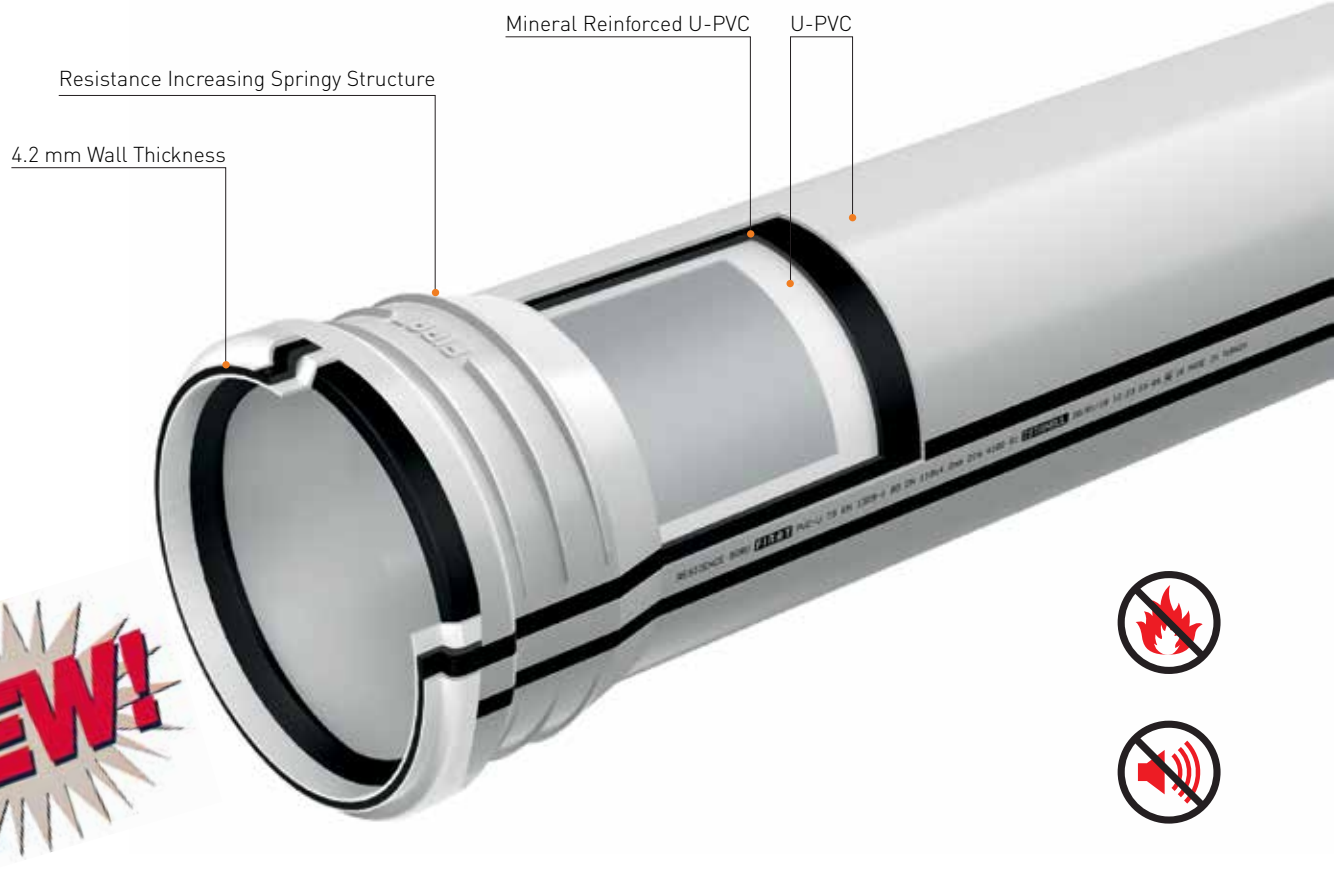

# New Residence Silent Power Pipes and Fittings

## Material Specifications

Residence Pipes And Fittings are produced in 3 layers with a mixture of U-PVC and vinyl-copolymer (FRvinylflex) raw materials. The inner Layer: is made of U-PVC with smooth inner surface. The middle Layer: FRvinylflex® is a mineral-based additive developed in Firat R&D laboratories which provides Residence pipes and fittings with soundproof features. The outer Layer: It is made of U-PVC which protects the pipe against external impacts.



## Seal

The seals used in Residence Pipes and Fittings are made from EPDM paste and thanks to their unidirectional and special outside shape they provide 100% impermeability. Produced according to TS EN 681-1 standard.



## Look

Residence Pipe and Fittings are produced in a grey colour. Feathered structure with increased impact resistance have been added to the muff sections.



## New Residence Silent Power Pipes and Fittings

### Physical And Chemical Properties

Residence Pipes and Fittings meet the mechanical and chemical properties mentioned in the TS EN 1329-1 standard.

### Residence Pipe Diameter And Wall Thicknesses

Equivalences Of The Fire Response Classes Of Building Materials Stated By The Relevant Eu Commission Decisions With The Flammability Classes Of Building Materials Specified In The Regulation On The Protection Of Buildings From Fire With Decision Number 2002/4390



### Standards And Test Reports For Residence Pipe And Fittings

- Meets the mechanical and physical requirements of BD class of the TS EN 1329-1 standard.

BD Implementation class covers in-building and surface application areas, in-building under the surface application areas, and application areas up to the sewer connection of the building.

- Residence Pipes and Fittings are of the non-flammable class within the scope of the "Regulation on Protection of Buildings from Fire" as stated in the 2007/12937 decision of the Ministry of Public Works and Settlement.

- As a result of the fire response performance test carried out at UL (Underwriters Laboratories), an independent US-based product safety certification agency, Residence Pipes and Fittings are categorized as V-0 NON-COMBUSTIBILITY class.

- TSE TEST AND CALIBRATION CENTRE EXAMINATION AND TEST REPORT Fire response classification of Residence Pipe and Fittings was found as B S2 D0 according to TS EN 13501-1 + A1: 2013-04 Fire Response Classification of Construction Products And Building Elements. Fire Class B, Smoke Formation S2, Flaming Droplets D0.



## New Residence Silent Power Pipes and Fittings

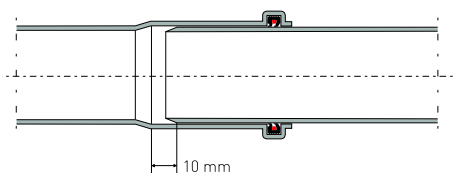
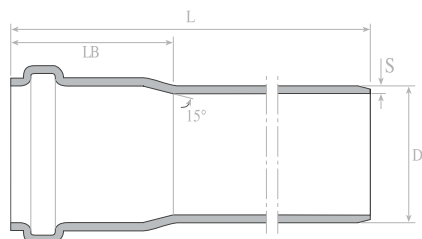

### NEW RESIDENCE SILENT POWER PIPES

CODE	ØD(mm)	Length L (mm)
7052050015	50	150
7052050025	50	250
7052050050	50	500
7052050100	50	1000
7052050200	50	2000
7052050300	50	3000
7052050600	50	6000
7052070015	75	150
7052070025	75	250
7052070050	75	500
7052070100	75	1000
7052070200	75	2000
7052070300	75	3000
7052070600	75	6000
7052100015	110	150
7052100025	110	250
7052100050	110	500
7052100100	110	1000
7052100200	110	2000
7052100300	110	3000
7052100600	110	6000
7052125015	125	150
7052125025	125	250
7052125050	125	500
7052125100	125	1000
7052125200	125	2000
7052125300	125	3000
7052125600	125	6000
7052150015	160	150
7052150025	160	250
7052150050	160	500
7052150100	160	1000
7052150200	160	2000
7052150300	160	3000
7052150600	160	6000

## New Residence Silent Power Pipes and Fittings

### ELBOW (45°)

CODE	ØD(mm)	d1(mm)	d2(mm)	S1(mm)	S2(mm)	S3(mm)
<b>7071050045</b>	50	50	50.3	3.0	2.7	2.3
<b>7071070045</b>	75	75	75.4	3.0	2.7	2.3
<b>7071100045</b>	110	110	110.4	3.2	2.9	2.4
<b>7071125045</b>	125	125	125.5	3.2	2.9	2.4
<b>7071150045</b>	160	150	160.5	4.0	3.6	3.0

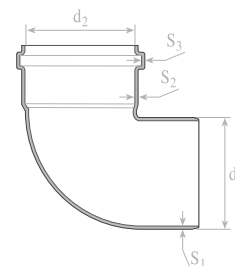

### ELBOW (87°)

CODE	ØD(mm)	d1(mm)	d2(mm)	S1(mm)	S2(mm)	S3(mm)
<b>7071050087</b>	50	50	50.3	3.0	2.7	2.3
<b>7071070087</b>	75	75	75.4	3.0	2.7	2.3
<b>7071100087</b>	110	110	110.4	3.2	2.9	2.4
<b>7071125087</b>	125	125	125.5	3.2	2.9	2.4
<b>7071150087</b>	160	150	160.5	4.0	3.6	3.0

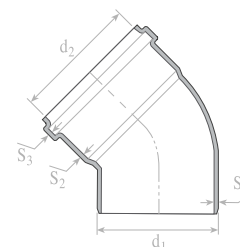

### T-PIECE

CODE	ØD(mm)	d1(mm)	d2(mm)	d3(mm)	S1(mm)	S2(mm)	S3(mm)
<b>7074050050</b>	50-50	50	50.3	50.3	3.0	2.7	2.3
<b>7074070050</b>	75-50	75	75.4	50.3	3.0	2.7	2.3
<b>7074070070</b>	75-75	75	75.4	75.4	3.0	2.7	2.3
<b>7074100050</b>	110-50	110	110.4	50.3	3.2	2.9	2.4
<b>7074100070</b>	110-75	110	110.4	75.4	3.2	2.9	2.4
<b>7074100100</b>	110-110	110	110.4	110.4	3.2	2.9	2.4
<b>7074125100</b>	125-110	125	125.5	110.4	3.2	2.9	2.4
<b>7074125125</b>	125-125	125	125.5	125.5	3.2	2.9	2.4
<b>7074150100</b>	160-110	160	160.6	110.4	4.0	3.6	3.0
<b>7074150125</b>	160-125	160	160.5	125.5	4.0	3.6	3.0
<b>7074150150</b>	160-160	160	160.5	160.5	4.0	3.6	3.0

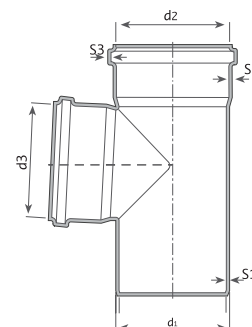

## New Residence Silent Power Pipes and Fittings

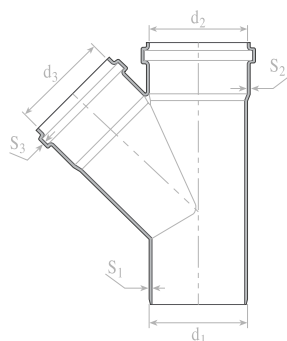

### SINGLE BRANCH (45°)

CODE	ØD(mm)	d1(mm)	d2(mm)	d3(mm)	S1(mm)	S2(mm)	S3(mm)
<b>7073050050</b>	50-50	50	50.3	50.3	3.0	2.7	2.3
<b>7073070050</b>	75-50	75	75.4	50.3	3.0	2.7	2.3
<b>7073070070</b>	75-75	75	75.4	75.4	3.0	2.7	2.3
<b>7073100050</b>	110-50	110	110.4	50.3	3.2	2.9	2.4
<b>7073100070</b>	110-75	110	110.4	75.4	3.2	2.9	2.4
<b>7073100100</b>	110-110	110	110.4	110.4	3.2	2.9	2.4
<b>7073125050</b>	125-50	125	125.5	50.3	3.2	2.9	2.4
<b>7073125070</b>	125-75	125	125.5	75.4	3.2	2.9	2.4
<b>7073125100</b>	125-110	125	125.5	110.4	3.2	2.9	2.4
<b>7073125125</b>	125-125	125	125.5	125.5	3.2	2.9	2.4
<b>7073150100</b>	160-110	160	160.6	110.4	4.0	3.6	3.0
<b>7073150125</b>	160-125	160	160.5	125.5	4.0	3.6	3.0
<b>7073150150</b>	160-160	160	160.5	160.5	4.0	3.6	3.0

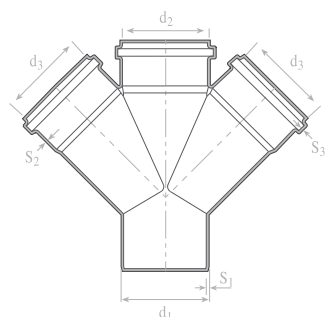

### DOUBLE BRANCH (45°-45°)

CODE	ØD(mm)	d1(mm)	d2(mm)	d3(mm)	S1(mm)	S2(mm)	S3(mm)
<b>7075050050</b>	50-50	50	50.3	50.3	3.0	2.7	2.3
<b>7075070050</b>	75-50	75	75.4	50.3	3.0	2.7	2.3
<b>7075070070</b>	75-75	75	75.4	75.4	3.0	2.7	2.3
<b>7075100050</b>	110-50	110	110.4	50.3	3.2	2.9	2.4
<b>7075100070</b>	110-75	110	110.4	75.4	3.2	2.9	2.4
<b>7075100100</b>	110-110	110	110.4	110.4	3.2	2.9	2.4
<b>7075125100</b>	125-110	125	125.5	110.4	3.2	2.9	2.4

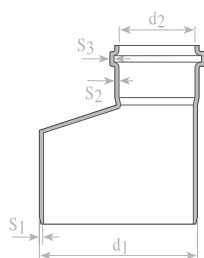

### REDUCER

CODE	ØD(mm)	d1(mm)	d2(mm)	S1(mm)	S2(mm)	S3(mm)
<b>7072070050</b>	75-50	75	50.3	3.3	2.7	2.3
<b>7072100050</b>	110-50	110	50.3	3.2	2.9	2.4
<b>7072100070</b>	110-75	110	75.4	3.2	2.9	2.4
<b>7072125070</b>	125-75	125	75.4	3.2	2.9	2.4
<b>7072125100</b>	125-110	125	110.4	3.2	2.9	2.4
<b>7072150100</b>	160-110	160	110.4	4.0	3.6	3.0
<b>7072150125</b>	160-125	160	125.5	4.0	3.6	3.0

## New Residence Silent Power Pipes and Fittings

### ACCESS T-PIECE

CODE	ØD(mm)	d2(mm)	S1(mm)	S2(mm)	S3(mm)
<b>7076001070</b>	75	75.4	3.0	2.9	2.4
<b>7076001100</b>	110	110.4	3.2	2.9	2.4
<b>7076001125</b>	125	125.5	3.2	3.6	2.4
<b>7076001150</b>	160	160.5	4.0	3.6	3.0

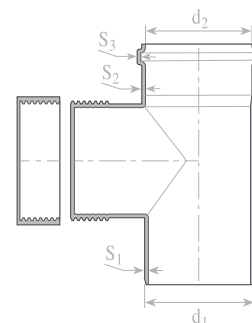

### SLIDING SOCKET

CODE	ØD(mm)	D(mm)	d1(mm)	S(mm)	L(mm)	L1(mm)
<b>7076007050</b>	50	50.3	59.6	3.0	84	58.4
<b>7076007070</b>	75	75.4	84.5	3.0	96	70.4
<b>7076007100</b>	110	110.4	120.6	3.2	130	98.8
<b>7076007125</b>	125	125.4	137.5	3.2	160	112.4
<b>7076007150</b>	160	160.5	174.3	4.0	170	125.0

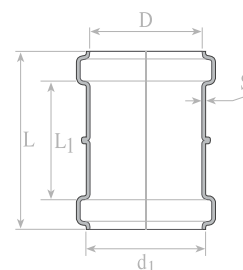

### S SIPHON

CODE	ØD(mm)	d1(mm)	d2(mm)	a(mm)	b(mm)	S(mm)
<b>7076003100</b>	110/45°	110	140	212	263	3.2

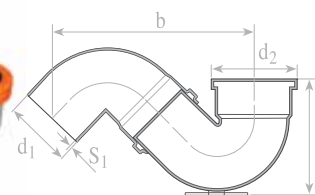

## New Residence Silent Power Pipes and Fittings

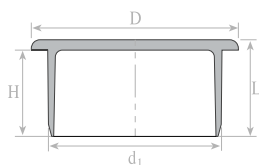

### PLUG

CODE	ØD(mm)	D(mm)	d1(mm)	L(mm)	H(mm)
<b>7076004050</b>	50	60	50	28	25
<b>7076004070</b>	75	85	75	34	30
<b>7076004100</b>	110	120	110	38	34
<b>7076004125</b>	125	138	125	40	45
<b>7076004150</b>	160	173	160	60	55

### BRACELETS (VERTICAL/ WITH BOLT NUT)



### BRACELETS (VERTICAL / WITH PIN BOLT)



## New Residence Silent Power Pipes and Fittings

**BRACELETS** (HORIZONTAL / WITH BOLT NUT)



**BRACELETS** (HORIZONTAL / WITH PIN BOLT)



## Residence Power Pipes and Fittings

FIRAT Residence Power Pipe and Fittings are perfect for a waste water system, with its sound-impermeable, perfect physical structure since it is made of mineral-additive FR VinylFlex and PVC rawmaterial mix.

Residence Power Pipe waste water system enables silent and reliable discharge of waste water (either due to foundation or facility itself) without any leakage, is environment-friendly and economic as well as converses its physical structure in any condition for longer product service life in villas, multi-storey residences, hospitals, schools, hotels and any industrial and sportive buildings, etc.

Thanks to its mineral-reinforced FR VinylFlex's special formula and perfect physical structure, Residence Power Pipe waste water systems prevent any noise by trapping hums and vibrations due to water movements inside the installation.

Residence Power Pipe waste water systems are produced at wall thickness of BD application type defined according to Quality Standards of TS 275-1 EN 1329-1. Residence Power Pipe waste water systems contribute in improving quality of your life as well as market value of your structure thanks to its installation easiness, anti-corrosive, smooth internal and external surfaces, maintenance-free, outstanding physical properties not allowing bacterial growth and smell formation and very low level of sound permeability, compared to its counterparts.

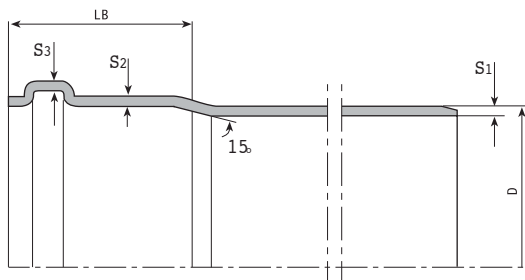

### Physical Specifications of Residence Pipes

Outer Diameter (mm)	S1 (mm)	S2 (mm)	S3 (mm)	LB	Weight (kg/m)
50	3.0	2.9	2.4	39.3	0.777
75	3.0	2.9	2.4	46.1	1.180
110	3.2	2.9	2.4	56.9	1.880
125	3.2	2.9	2.4	62.8	2.014
160	4.0	3.6	3.0	75.8	3.046
200	4.9	4.4	3.7	89.4	5.240
250	6.2	5.6	4.7	112.6	8.470
315	7.7	6.9	5.8	135.4	13.420

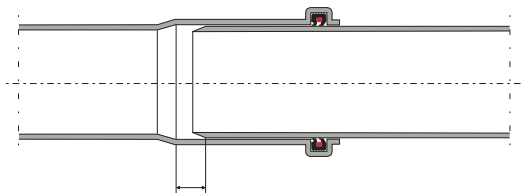

# Residence Power Pipes and Fittings

## Residence Power Pipe Noise-Dampening

Produced with the rawmaterial developed in the Firat R&D laboratories by combining mineral reinforced vinyl-copolymer which has noise dampening feature (FRVinylFlex®) with PVC, Residence Power Pipe and Fittings has high sound isolation performance.

Mineral-reinforced Residence Power Pipe and Fittings both absorb the contact sound as well as prevent sound passage.

## Residence Power Pipe Sound Measurement Performance

According to test report no P-BA 59/2008e dated as 18.02.2008 of German Fraunhofer Building Physics Institute sound performance, the characteristics body sound measurement performance is 10 dB of waste water installation with Firat Residence Power Pipe and Fittings at PVC-U BD SN4\* 3.2 mm of wall thickness and 110 mm of diameter at 0.5 l/s water flow.

\* Residence Power Pipe and Fittings are produced at wall thickness of BD application type defined according to Quality Standards of TS 275-1 EN 1329-1.

POWER PIPE 110 Pipe and 110 CLAMP Waste Water System Test 1				
Flow Rate [l/s]	0,5	1,0	2,0	4,0
Characteristics body sound spread LSC, A[dB(A)]	10	14	19	24

FIRAT Residence Power Pipe, FIRAT Residence Power Pipe fittings and FIRAT Residence Power Pipe clamps manufactured in FIRAT plants were employed in leak tests performed in IBP Fraunhofer Structure Physics Institute.

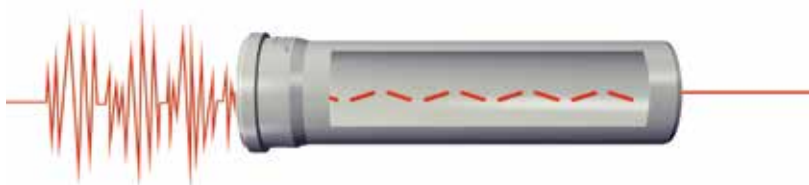

## Residence Power Pipes and Fittings

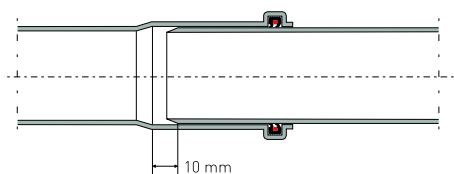
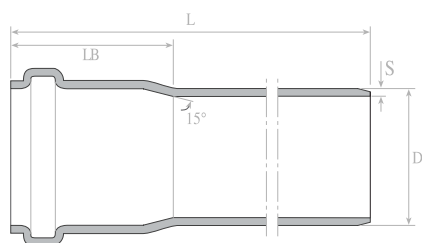

### RESIDENCE POWER PIPES

CODE	ØD(mm)	Length L (mm)
7050050015	50	150
7050050025	50	250
7050050050	50	500
7050050100	50	1000
7050050200	50	2000
7050050300	50	3000
7050050600	50	6000
7050070015	75	150
7050070025	75	250
7050070050	75	500
7050070100	75	1000
7050070200	75	2000
7050070300	75	3000
7050070600	75	6000
7050100015	110	150
7050100025	110	250
7050100050	110	500
7050100100	110	1000
7050100200	110	2000
7050100300	110	3000
7050100600	110	6000
7050125015	125	150
7050125025	125	250
7050125050	125	500
7050125100	125	1000
7050125200	125	2000
7050125300	125	3000
7050125600	125	6000
7050150015	160	150
7050150025	160	250
7050150050	160	500
7050150100	160	1000
7050150200	160	2000
7050150300	160	3000
7050150600	160	6000
7050200015	200	150
7050200025	200	250
7050200050	200	500
7050200100	200	1000
7050200200	200	2000
7050200300	200	3000
7050200600	200	6000
7050250015	250	150
7050250025	250	250
7050250050	250	500
7050250100	250	1000
7050250200	250	2000
7050250300	250	3000
7050250600	250	6000
7050315050	315	500
7050315100	315	1000
7050315200	315	2000
7050315300	315	3000
7050315600	315	6000

# Residence Power Pipes and Fittings

## ELBOW (45°)

CODE	ØD(mm)	d1(mm)	d2(mm)	S1(mm)	S2(mm)	S3(mm)
7061050045	50	50	50.3	3.0	2.7	2.3
7061075045	75	75	75.4	3.0	2.7	2.3
7061100045	110	110	110.4	3.2	2.9	2.4
7061125045	125	125	125.5	3.2	2.9	2.4
7061160045	160	150	160.5	4.0	3.6	3.0
7061200045	200	200	200.6	4.9	4.4	3.7
7061250045	250	250	250.6	6.2	5.6	4.7

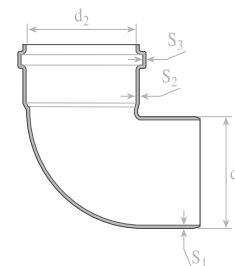

## ELBOW (87°)

CODE	ØD(mm)	d1(mm)	d2(mm)	S1(mm)	S2(mm)	S3(mm)
7061050087	50	50	50.3	3.0	2.7	2.3
7061070087	75	75	75.4	3.0	2.7	2.3
7061100087	110	110	110.4	3.2	2.9	2.4
7061125087	125	125	125.5	3.2	2.9	2.4
7061150087	160	150	160.5	4.0	3.6	3.0
7061200087	200	200	200.6	4.9	4.4	3.7
7061250087	250	250	250.6	6.2	5.6	4.7

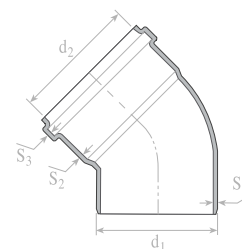

## T-PIECE

CODE	ØD(mm)	d1(mm)	d2(mm)	d3(mm)	S1(mm)	S2(mm)	S3(mm)
7064050050	50-50	50	50.3	50.3	3.0	2.7	2.3
7064070050	75-50	75	75.4	50.3	3.0	2.7	2.3
7064070070	75-75	75	75.4	75.4	3.0	2.7	2.3
7064100050	110-50	110	110.4	50.3	3.2	2.9	2.4
7064100070	110-75	110	110.4	75.4	3.2	2.9	2.4
7064100100	110-110	110	110.4	110.4	3.2	2.9	2.4
70K6412505*	125-50	125	125.5	50.3	3.2	2.9	2.4
70K6412507*	125-75	125	125.5	75.4	3.2	2.9	2.4
7064125100	125-110	125	125.5	110.4	3.2	2.9	2.4
7064125125	125-125	125	125.5	125.5	3.2	2.9	2.4
70K6415005*	160-50	160	160.6	50.4	4.0	3.6	3.0
70K6415007*	160-75	160	160.6	75.4	4.0	3.6	3.0
7064150100	160-110	160	160.6	110.4	4.0	3.6	3.0
7064150125	160-125	160	160.5	125.5	4.0	3.6	3.0
7064150150	160-160	160	160.5	160.5	4.0	3.6	3.0
70K6420010*	200-110	200	200.7	110.5	4.9	4.4	3.7
70K6420012*	200-125	200	200.7	125.5	4.9	4.4	3.7
70K6420015*	200-160	200	200.7	160.6	4.9	4.4	3.7
7064200200	200-200	200	200.7	200.7	4.9	4.4	3.7
70K6425015*	250-150	250	250.6	160.6	6.2	5.6	4.7
70K6425020*	250-200	250	250.6	200.7	6.2	5.6	4.7
7064250250	250-250	250	250.6	250.6	6.2	5.6	4.7

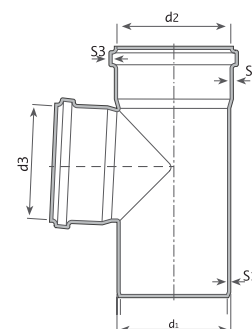

K: Confection Production

## Residence Power Pipes and Fittings

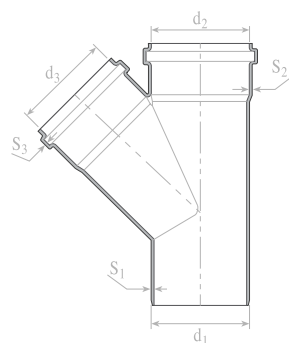
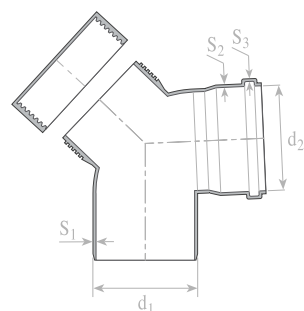
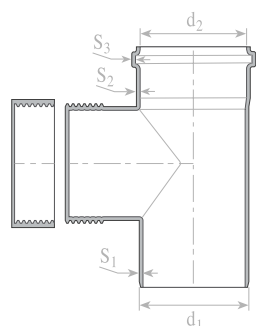

### ACCESS T-PIECE

CODE	ØD(mm)	d2(mm)	S1(mm)	S2(mm)	S3(mm)
<b>7066001070</b>	75	75.4	3.0	2.9	2.4
<b>7066001100</b>	110	110.4	3.2	2.9	2.4
<b>7066001125</b>	125	125.5	3.2	3.6	2.4
<b>7066001150</b>	160	160.5	4.0	3.6	3.0
<b>7066001200</b>	200	200.6	4.9	4.4	3.7

### CLEAN OUT ELBOW

CODE	ØD(mm)	d2(mm)	S1(mm)	S2(mm)	S3(mm)
<b>7066001110</b>	110	110.4	3.2	2.9	2.9

### SINGLE BRANCH (45°)

CODE	ØD(mm)	d1(mm)	d2(mm)	d3(mm)	S1(mm)	S2(mm)	S3(mm)
<b>7063050050</b>	50-50	50	50.3	50.3	3.0	2.7	2.3
<b>7063070050</b>	75-50	75	75.4	50.3	3.0	2.7	2.3
<b>7063070070</b>	75-75	75	75.4	75.4	3.0	2.7	2.3
<b>7063100050</b>	110-50	110	110.4	50.3	3.2	2.9	2.4
<b>7063100070</b>	110-75	110	110.4	75.4	3.2	2.9	2.4
<b>7063100100</b>	110-110	110	110.4	110.4	3.2	2.9	2.4
<b>7063125050</b>	125-50	125	125.5	50.3	3.2	2.9	2.4
<b>7063125070</b>	125-75	125	125.5	75.4	3.2	2.9	2.4
<b>7063125100</b>	125-110	125	125.5	110.4	3.2	2.9	2.4
<b>7063125125</b>	125-125	125	125.5	125.5	3.2	2.9	2.4
<b>7063150050</b>	160-50	160	160.6	50.4	4.0	3.6	3.0
<b>7063150070</b>	160-75	160	160.6	75.4	4.0	3.6	3.0
<b>7063150100</b>	160-110	160	160.6	110.4	4.0	3.6	3.0
<b>7063150125</b>	160-125	160	160.5	125.5	4.0	3.6	3.0
<b>7063150150</b>	160-160	160	160.5	160.5	4.0	3.6	3.0
<b>7063200100</b>	200-110	200	200.7	110.5	4.9	4.4	3.7
<b>70K6320012*</b>	200-125	200	200.7	125.5	4.9	4.4	3.7
<b>7063200150</b>	200-160	200	200.7	160.6	4.9	4.4	3.7
<b>7063200200</b>	200-200	200	200.7	200.7	4.9	4.4	3.7
<b>70K6325015*</b>	250-150	250	250.6	160.6	6.2	5.6	4.7
<b>70K6325020*</b>	250-200	250	250.6	200.7	6.2	5.6	4.7
<b>7063250250</b>	250-250	250	250.6	250.6	6.2	5.6	4.7

K: Confection Production

# Residence Power Pipes and Fittings

## REDUCER

CODE	ØD(mm)	d1(mm)	d2(mm)	S1(mm)	S2(mm)	S3(mm)
7062070050	75-50	75	50.3	3.3	2.7	2.3
7062100050	110-50	110	50.3	3.2	2.9	2.4
7062100070	110-75	110	75.4	3.2	2.9	2.4
7062125070	125-75	125	75.4	3.2	2.9	2.4
7062125100	125-110	125	110.4	3.2	2.9	2.4
7062150100	160-110	160	110.4	4.0	3.6	3.0
7062150125	160-125	160	125.5	4.0	3.6	3.0
7062200100	200-110	200	110.4	4.9	4.4	3.7
7062200125	200-125	200	125.5	4.9	4.4	3.7
7062200150	200-160	200	160.5	4.9	4.4	3.7
7062250200	250-200	250	200.6	6.2	4.4	3.7

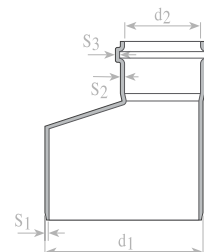

## CROSS-T

CODE	ØD(mm)	d-d1(mm)	d2-d3(mm)	S1(mm)	S2(mm)	S3(mm)
7064500100	110	110	110.4	3.2	2.9	2.4

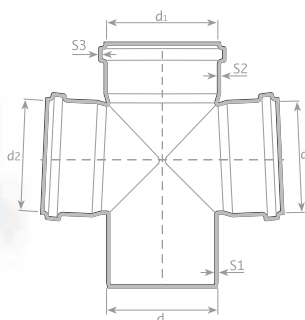

## DOUBLE BRANCH (45°-45°)

CODE	ØD(mm)	d1(mm)	d2(mm)	d3(mm)	S1(mm)	S2(mm)	S3(mm)
7065050050	50-50	50	50.3	50.3	3.0	2.7	2.3
7065070050	75-50	75	75.4	50.3	3.0	2.7	2.3
7065070070	75-75	75	75.4	75.4	3.0	2.7	2.3
7065100050	110-50	110	110.4	50.3	3.2	2.9	2.4
7065100070	110-75	110	110.4	75.4	3.2	2.9	2.4
7065100100	110-110	110	110.4	110.4	3.2	2.9	2.4
70K6512505*	125-50	125	125.5	50.3	3.2	2.9	2.4
70K6512507*	125-75	125	125.5	75.4	3.2	2.9	2.4
7065125100	125-110	125	125.5	110.4	3.2	2.9	2.4
70K6512512*	125-125	125	125.5	125.5	3.2	2.9	2.4
70K6515005*	160-50	160	160.6	50.4	4.0	3.6	3.0
70K6515007*	160-75	160	160.6	75.4	4.0	3.6	3.0
70K6515010*	160-110	160	160.6	110.4	4.0	3.6	3.0
70K6515012*	160-125	160	160.5	125.5	4.0	3.6	3.0
70K6515015*	160-160	160	160.5	160.5	4.0	3.6	3.0
70K6520010*	200-110	200	200.7	110.5	4.9	4.4	3.7
70K6520012*	200-125	200	200.7	125.5	4.9	4.4	3.7
70K6520015*	200-160	200	200.7	160.6	4.9	4.4	3.7
70K6520020*	200-200	200	200.6	200.6	4.9	4.4	3.7
70K6525025*	250-250	250	250.6	250.6	6.2	5.6	4.7

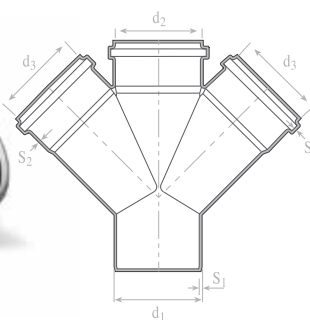

K: Confection Production

## Residence Power Pipes and Fittings

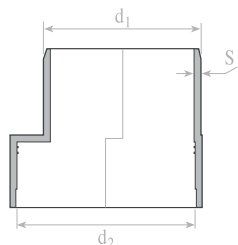

### WC CONNECTOR

CODE	ØD(mm)	d1(mm)	d2(mm)	S3(mm)
<b>7066002100</b>	110	110	131.0	3.2

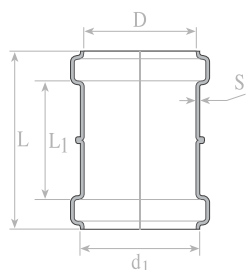

### SLIDING SOCKET

CODE	ØD(mm)	D(mm)	d1(mm)	S(mm)	L(mm)	L1(mm)
<b>7066007050</b>	50	50.3	59.6	3.0	84	58.4
<b>7066007070</b>	75	75.4	84.5	3.0	96	70.4
<b>7066007100</b>	110	110.4	120.6	3.2	130	98.8
<b>7066007125</b>	125	125.4	137.5	3.2	160	112.4
<b>7066007150</b>	160	160.5	174.3	4.0	170	125.0

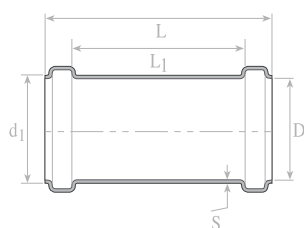

### SOCKET

CODE	ØD(mm)	D(mm)	d1(mm)	S(mm)	L(mm)	L1(mm)
<b>7066006125</b>	125	125.4	137.5	3.2	480	420
<b>7066006150</b>	160	160.5	174.3	4.0	480	420
<b>7066006200</b>	200	200.6	216.7	4.9	760	700

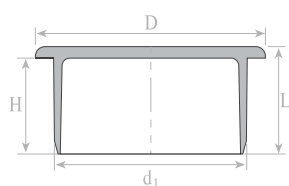

### PLUG

CODE	ØD(mm)	D(mm)	d1(mm)	L(mm)	H(mm)
<b>7066004050</b>	50	60	50	28	25
<b>7066004070</b>	75	85	75	34	30
<b>7066004100</b>	110	120	110	38	34
<b>7066004125</b>	125	138	125	40	45
<b>7066004150</b>	160	173	160	60	55
<b>7066004200</b>	200	214	200	71	65

## Residence Power Pipes and Fittings

### S SIPHON

CODE	ØD(mm)	d1(mm)	d2(mm)	a(mm)	b(mm)	S(mm)
7066002145	75/45°	75	97	150	202	3.0
7066002175	75/87°	75	97	150	195	3.0
7066003145	100	110	140	212	290	3.2
7066003175	110/45°	110	140	212	263	3.2

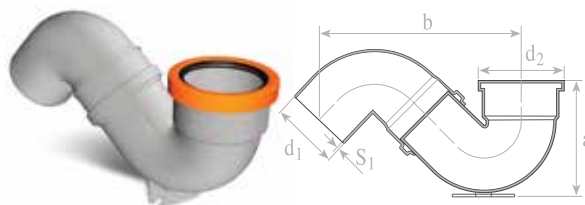

### S SIPHON WITH MUFF

CODE	ØD(mm)	d1(mm)	d2(mm)	a(mm)	b(mm)	S(mm)
7067000100	110	110	126	176	167	3.2
7067000145	110/45°	110	126	178	268	3.2

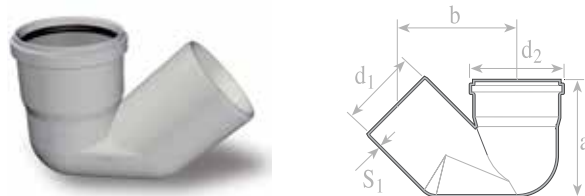

### BRACELETS

CODE	ØD(mm)	A(mm)	B(mm)
7066007050	50	78.30	57.60
7066007070	75	118.20	83.60
7066007100	110	152.55	120.00
7066007125	125	159.50	167.65
7066007150	160	207.60	207.45

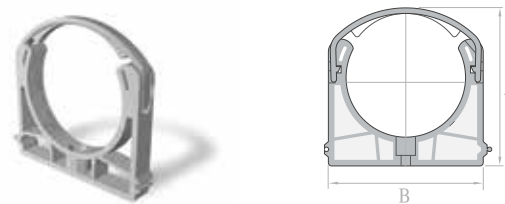

### ADAPTING SEAL

CODE	ØD(mm)
7066005050	50





# Pvc Decorative Rain Gutter And Fittings

## SOCKET

**CODE**

**7042100006**

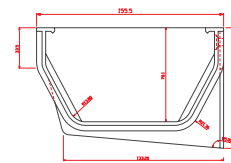

## ELBOW (90°)

**CODE**

**7042100007**

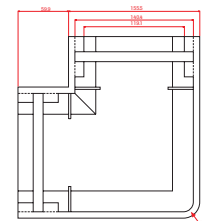

## T CONNECTION (Rectangle)

**CODE**

**7042100008**

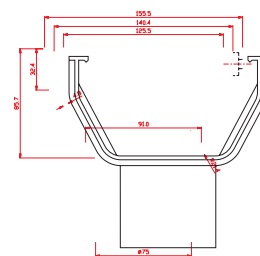

## T CONNECTION (Ø70 / Round)

**CODE**

**7042100009**

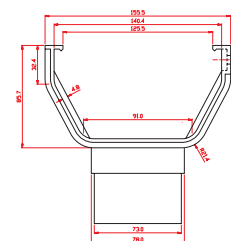

## DOWN PIPE SOCKET

**CODE**

**7042100012**

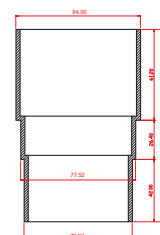





# Pvc Corner Shaped Rain Gutter And Fittings

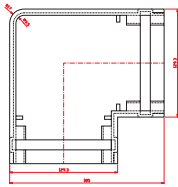

**ELBOW** (90° internal and external corners)

**CODE**  
7042100015

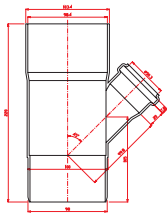

**SINGLE BRANCH** (45°)

**CODE**  
7042140007

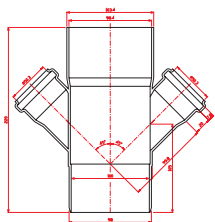

**DOUBLE BRANCH** (45°-45°)\*

**CODE**  
70K1015005  
\* Fabricated

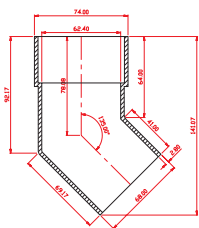

**DOWN ELBOW** (45°)

**CODE**  
7042140006

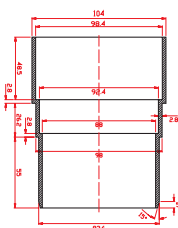

**DOWN PIPE SOCKET**

**CODE**  
7042140008

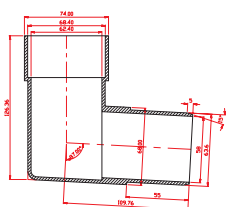

**DOWN ELBOW** (90°)

**CODE**  
7042140012

# Pvc Corner Shaped Rain Gutter And Fittings

## DOWN PIPE REDUCER (150-110)

**CODE**

7042140016

7042140015

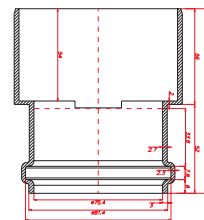

## DOWN PIPE REDUCER (150-70)

**CODE**

7042140017

7042140014

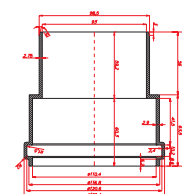

## GUTTER END CAP

**CODE**

7042140005

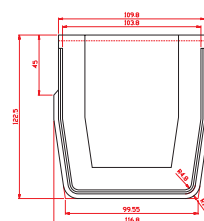

## RAIN GUTTER BRACELET

**CODE**

7042140011

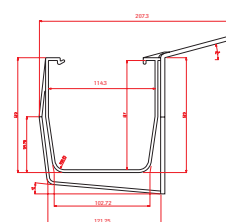

## DOWN PIPE BRACELET

**CODE**

7042140009

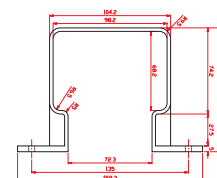

## DOWN PIPE BRACELET WITH LOCK

**CODE**

7042140013

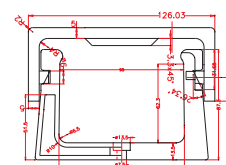

## HDPE Pipes and LDPE Pipes



### Polyethylene Rawmaterial

Advancements in the technology ensured that important advancements were also realized in plastic raw material production. Low density polyethylene (PE 32-LDPE) which was developed in 1950's were firstly used for potable water piping. Later, with the development of PE 63 raw material, application in systems which do not require high pressure was realized successfully. However, it was only possible to use PE 63 in natural gas systems which require low pressure (maximum 4 bars) due to its technical properties. PE manufacturers launched PE 80 rawmaterial as 2nd generation after PE 63. Thus, it was possible to use PE 80 rawmaterial in potable water and natural gas networks with high performance. 3rd generation PE 100 rawmaterial which was developed in the beginning of 1990s offered higher performance and an economical solution for potable water, utility water and natural gas networks.

FIRAT PLASTİK A.Ş. manufactures PE 100 pipes between diameters of Ø 20 - Ø 1600 mm, PE 80 natural gas pipes between diameters of Ø 20 - Ø 630 mm and PE 40 MDPE potable water pipes between diameters of Ø 20 - Ø 110 mm.



PE pipes are produced in coils up to Ø 125 mm, diameters equal to Ø 125 mm and higher are produced in 12 m length, additionally, custom productions can be carried out.

### Advantages of Polyethylene Piping

- They have high flexibility features. Thus, they ensure ease of installation. Elongation at break is minimum 350%.
- They are not affected from underground movements, they do not break.
- They have high impact resistance and rapid crack propagation resistance.
- Since they have low interior surface roughness, they ensure significant advantages while selecting diameter during project design.
- They are suitable for installing on sea bottom, they are not affected from sea water and sea movements.
- They do not have installation wastage thanks to the joining method.
- Black colored pipes are resistant to UV rays.
- They are not affected from harmful substances which are contained in the structure of soil that cause abrasive effects. Therefore, cathode protection is not required.
- They are resistant to chemical substances.
- They do not change odor and taste of water, therefore, fit for health.
- It is not possible for plant and tree roots to penetrate inside the pipes.



## HDPE Pipes and LDPE Pipes

### HDPE PIPES - PN6 (Darkblue)

CODE	ØD <sub>(mm)</sub>	Length (m)
750060020L	20	100
750060025L	25	100
750060032L	32	100
750060040L	40	100
750060050L	50	100
750060063L	63	100
750060075L	75	100
750060090L	90	100



### HDPE PIPES - PN10 (Darkblue)

CODE	ØD <sub>(mm)</sub>	Length (m)
7500100020L	20	100
7500100025L	25	100
7500100032L	32	100
7500100040L	40	100
7500100050L	50	100
7500100063L	63	100
7500100075L	75	100
7500100090L	90	100



### LDPE PIPES - PN6 (Blue-White)

CODE	ØD <sub>(mm)</sub>	Length (m)
7501060020M	20	100
7501060025M	25	100
7501060032M	32	100
7501060040M	40	100
7501060050M	50	100
7501060063M	63	100
7501060075M	75	100



### LDPE PIPES - PN10 (Blue-White)

CODE	ØD <sub>(mm)</sub>	Length (m)
7501100020M	20	100
7501100025M	25	100
7501100032M	32	100
7501100040M	40	100
7501100050M	50	100
7501100063M	63	100
7501100075M	75	100
7501100090M	90	100

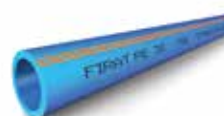

# Hoses



## Do's and Don'ts in hoses

- Hoses which are in coil shape, should be stored horizontally and properly in order to avoid deformity.
- The temperature should be between 10-30 °C in storage area.
- Hoses that are stored in low temperature areas should be allowed to reach normal environmental temperature before usage. (Low temperature makes hoses stiff).
- Hoses should not be used at higher working temperatures and working pressures that are specified at technical catalogue.
- Hoses should be protected against stroke.

### GREEN SUCTION & BLOWING HOSES (Flex)



CODE	WORKING PRESSURE	G"
<b>7322000254Y</b>	6 Bar	1"
<b>7322000318Y</b>	6 Bar	1.1/4"
<b>7322000381Y</b>	6 Bar	1.1/2"
<b>7322000508Y</b>	5 Bar	2"
<b>7322000635Y</b>	5 Bar	2.1/2"
<b>7322000762Y</b>	5 Bar	3"
<b>7322001016Y</b>	5 Bar	4"

### YELLOW SUCTION & BLOWING HOSES (Flex)



CODE	WORKING PRESSURE	G"
<b>7323000254S</b>	5 Bar	1"
<b>7323000318S</b>	5 Bar	1.1/4"
<b>7323000381S</b>	5 Bar	1.1/2"
<b>7323000508S</b>	4 Bar	2"
<b>7323000635S</b>	4 Bar	2.1/2"
<b>7323000762S</b>	4 Bar	3"
<b>7323001016S</b>	4 Bar	4"

### RED SUCTION & BLOWING HOSES (Flex)



CODE	WORKING PRESSURE	G"
<b>7324000254K</b>	4 Bar	1"
<b>7324000318K</b>	4 Bar	1.1/4"
<b>7324000381K</b>	4 Bar	1.1/2"
<b>7324000508K</b>	4 Bar	2"
<b>7324000635K</b>	4 Bar	2.1/2"
<b>7324000762K</b>	4 Bar	3"
<b>7324001016K</b>	4 Bar	4"

# Hoses

## TRANSPARENT WATER HOSES (Flex)

CODE	WORKING PRESSURE	G"
7321000191	19 Bar	3/4"
7321000254	25 Bar	1"
7321000290	29 Bar	1.1/7"
7321000318	32 Bar	1.1/4"
7321000381	38 Bar	1.1/2"



## DUST AIR HOSES (Flex)

CODE	G"
7325001016	4"



## TRANSPARENT HOSES (Super Extra)

CODE	WORKING PRESSURE	G"
7301000127	6 Bar	1/2"
7301000159	6 Bar	5/8"
7301000191	6 Bar	3/4"
7301000254	5 Bar	1"
7301000318	5 Bar	1.1/4"
7301000381	5 Bar	1.1/2"
7301000508	5 Bar	2"



## TRANSPARENT HOSES (Milimetric)

CODE	DIAMETERS
7301000040	4 mm
7301000050	5 mm
7301000060	6 mm
7301000080	8 mm
7301000100	10 mm



## AUTOMATIVE INDUSTRIAL TRANSPARENT HOSES

CODE	DIAMETERS
7302004008	4 x 8
7302005009	5 x 9
7302006010	6 x 10
7302007012	7 x 12
7302008013	8 x 13
7302009014	9 x 14
7302010016	10 x 16



# Hoses



## BRAIDED GARDEN HOSES (Meteor)

CODE	WORKING PRESSURE	G"
<b>7420000127</b>	4 Bar	1/2"
<b>7420000159</b>	4 Bar	5/8"
<b>7420000191</b>	4 Bar	3/4"
<b>7420000254</b>	4 Bar	1"



## BRAIDED TRANSPARENT HOSES

CODE	WORKING PRESSURE	G"
<b>7351000127</b>	4 Bar	1/2"
<b>7351000159</b>	4 Bar	5/8"
<b>7351000191</b>	4 Bar	3/4"
<b>7351000254</b>	4 Bar	1"
<b>7351000318</b>	4 Bar	1.1/4"



## NEW GARDEN HOSES

CODE	WORKING PRESSURE	G"
<b>7354000127</b>	4 Bar	1/2"
<b>7354000159</b>	4 Bar	5/8"
<b>7354000191</b>	4 Bar	3/4"
<b>7354000254</b>	4 Bar	1"
<b>7354000318</b>	4 Bar	1.1/4"



## DOUBLE BRAIDED HOSES

CODE	G"
<b>7358000127K</b>	1/2"
<b>7358000127S</b>	1/2"

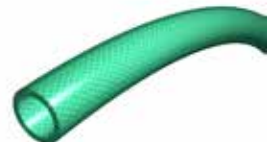

## BRAIDED TRANSPARENT HOSES (Çınar)

CODE	WORKING PRESSURE	G"
<b>7350000127</b>	19	1/2"
<b>7350000159</b>	25	5/8"
<b>7350000191</b>	29	3/4"
<b>7350000254</b>	32	1"
<b>7350000318</b>	38	1.1/4"

# Hoses

## SOFT HOSES (Eco)

CODE	G"
7408100001	1/2"
7408100002	5/8"
7408100003	3/4"
7408100004	1"
7408100005	1.1/4"



## SOFT HOSES (Firat)

CODE	WORKING PRESSURE	G"
7408000001	4 Bar	1/2"
7408000002	4 Bar	5/8"
7408000003	4 Bar	3/4"
7408000004	4 Bar	1"
7408000005	4 Bar	1.1/4"



## BRAIDED SOFT HOSES

CODE	WORKING PRESSURE	G"
7408200001	4 Bar	1/2"



## TRANSPARENT WATER HOSES (Çınar)

CODE	G"
7321001254	1"
7321001290	1.1/7"
7321001318	1.1/4"



## AIR CONDITIONER HOSES

CODE	WORKING PRESSURE	G"
7303050849	2 Bar	5/8"



# Hoses



## WASHING MACHINE INLET HOSES (Red-Blue)

CODE	WORKING PRESSURE	LENGTH
<b>7400100150</b>	10 Bar	1.5 m
<b>7400100200</b>	10 Bar	2 m
<b>7400100250</b>	10 Bar	2.5 m
<b>7400100300</b>	10 Bar	3 m
<b>7400100400</b>	10 Bar	4 m
<b>7400100500</b>	10 Bar	5 m



## WASHING MACHINE OUTLET HOSES

CODE	LENGTH
<b>7409117503</b>	1.5 m
<b>7409117504</b>	2 m
<b>7409117505</b>	2.5 m
<b>7409117506</b>	3 m



## GAS HOSES

CODE	DIAMETER
<b>7307080000</b>	8 mm
<b>7307100000</b>	10 mm



## BRAIDED GAS HOSES

CODE	DIAMETER
<b>7357000060</b>	6 mm
<b>7357000080</b>	8 mm
<b>7357000100</b>	10 mm

# Hoses

## THERMORUBBER WATER HOSES (Green/Black - Burst Pressure: 60 atm)

Black-KCODE	Green-CODE	WORKING PRESSURE	G"
7401000127	7401000127Y	6 Bar	1/2"
7401000159	7401000159Y	6 Bar	5/8"
7401000191	7401000191Y	6 Bar	3/4"
7401000254	7401000254Y	6 Bar	1"
7401000318	7401000318Y	6 Bar	1.1/4"



## THERMORUBBER OXYGEN HOSES (Red/Blue-Burst Pressure: 60 atm)

CODE	DIAMETER	WORKING PRESSURE	G"
7402000060	6 mm	20 Bar	1/4"
7402000080	8 mm	20 Bar	5/16"
7402000100	10 mm	20 Bar	3/8"



## THERMORUBBER COMPRESSOR HOSES (Burst Pressure: 60 atm)

CODE	WORKING PRESSURE	G"
7404000127	20 Bar	1/2"
7404000159	20 Bar	5/8"
7404000191	20 Bar	3/4"



## THERMORUBBER COMPRESSOR HOSES (Burst Pressure: 200 atm)

CODE	WORKING PRESSURE	DIAMETER
7405000100	80 Bar	10 mm
7405000120	50 Bar	12 mm



## FIRE HOSES

CODE	WORKING PRESSURE	G"
7406000254	12 Bar	1"
7406020254	12 Bar	1"
7406025254	12 Bar	1"
7406030254	12 Bar	1"
7406040254	12 Bar	1"
7406050254	12 Bar	1"
7406060254	12 Bar	1"



# Drainage Pipes

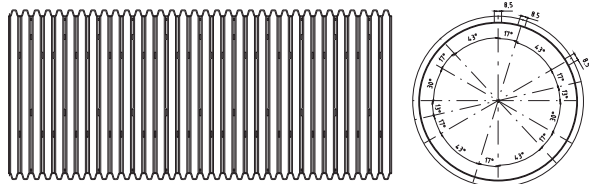

Conforming to TS 9128 and DIN 1187 standards, Firat PVC-U Drainage Pipes are available in diameters of 80, 110, 125, 160 and 200 mm. Width of water input openings of PVC-U Drainage Pipes, which are manufactured from PVC-U raw material, falls within medium size ( $1.2 \pm 0.2$  mm) as specified by TS 9128 standard. Used safely under heavy chemical conditions, Firat PVC-U Drainage Pipes have a minimum lifespan of 50 years.

### Areas of Use

- Protection of buildings and structures which have water in the foundation
- For highway banquet drainages
- Infrastructure of sports arenas (grass pitch, courts, tracks)
- Improvement of muddy and sludgy areas
- Removal of unwanted waters in agriculture

### Physical Specifications of Drainage PVC-U Pipes

Diameter (mm)	Outer Diameter* (mm/minimum)	Internal Diameter (mm)	Minimum Coil Reeling Diameter (mm)
80	$80 \pm 0.5$	71.5	600
110	$100 \pm 0.5$	91	700
125	$122.5 \pm 0.5-1$	115	750
160	$155.3 \pm 0.5-1$	144	1000
200	$199.5 \pm 0.5-$	182	1000

### DRAINAGE PIPES\*

CODE	DIAMETER
<b>712000001</b>	80
<b>712000002</b>	110
<b>712000003</b>	125
<b>712000004</b>	160
<b>712000005</b>	200

\* Shipping is covered by the consignee in drainage pipes.

### DRAINAGE PIPES\*

CODE	DIAMETER
<b>712000011</b>	80
<b>712000012</b>	110
<b>712000013</b>	125
<b>712000014</b>	160
<b>712000015</b>	200

\* Shipping is covered by the consignee in drainage pipes.

# Our Quality Certificates



## **FIRAT sells to a lot of Countries in Europe, America, Asia and Africa**

### **Countries to which FIRAT Exports:**

Afghanistan	Macedonia
Algeria	Moldova
Armenia	Mongolia
Azerbaijan	Montenegro
Bahrain	Morocco
belarus	Netherlands
Belgium	New Zeland
Bosnia	Nigeria
Brazil	Pakistan
Britain	Poland
Bulgaria	Portugal
China	Romania
Croatia	Russia
Cyprus	Saudi Arabia
Egypt	Serbia
Ethiopia	Slovenia
Finland	South Africa
France	Spain
Gabon	Sri Lanka
Gambia	Sudan
Georgia	Surinam
Germany	Swedish
Ghana	Syria
Greece	Tajikistan
Hungary	Train
Iceland	Tunisian
India	Turkmenistan
Iranian	Ukraine
Iraq	United Arab Emirates
Italy	Uzbekistan
Jordan	Venezuelan
Kazakhstan	Yemen
Kenya	
Kirghizistan	
Kosovo	
Kuwait	
Latvia	
Lebanon	
Libya	



# FIRAT

Türkoba Mahallesi  
Firat Plastik Caddesi No:23  
34537 Büyükçekmece İstanbul / TURKEY  
T: +90 (212) 866 41 41 - 866 42 42  
F: +90 (212) 859 04 00 - 859 05 00

**firat.com**

[f](#) /firatplastik

[t](#) /firatplastik

[in](#) /firatplastik

[firat@firat.com](mailto:firat@firat.com)

[info@firat.com](mailto:info@firat.com)

**Müşteri Danışma Hattı**  
**4 4 4 9 FRT**  
**0 800 219 80 20**  
**0 800 219 83 78**

Firat Plastik Kauçuk Sanayi ve Ticaret A.Ş.  
herhangi bir bildirimde bulunmaksızın  
bu broşürde her türlü değişiklik yapma  
hakkını saklı tutar.